





531 – 591 WINDOW INSTALLATION MANUAL

VPI QUALITY WINDOWS
3420 E Ferry Ave. Spokane WA. 99202

TABLE OF CONTENTS

- Part 1) Standard 3.5" Frame 3
 - A) Preface 3
 - B) Tools and Materials 3
 - C) Rough Opening preparation 4
 - D) Unit Preparation 5
 - E) Installation Standards 5
 - F) Install and fasten 6
 - G) Final Adjustment 13
- Part 2) Deep Backset 6" frame 14
 - A) Preface 14
 - B) Nail fin 1" backset from exterior face details 15
 - C) Nail fin 1.375" backset from exterior face details 16
 - D) Nail fin 3.875" backset from exterior face details 17
 - E) No fin 18





Legend:

	Caution
	Quality
	Safety
RO	Rough Opening
WRB	Water Resistant Barrier
PVC	Polyvinyl Chloride

Always read the Vinyl Window and Door Limited Warranty before purchasing or installing Vinyl Windows and Doors manufactured by VPI Quality Windows. By installing this product, you are acknowledging that this Limited Warranty is part of the terms of the sale. Failure to comply with all VPI Quality Windows and maintenance instructions may void your VPI Quality Windows warranty. See Limited Warranty for complete details at <http://www.vpiwindows.com/>

Part 1) STANDARD 3.5" FRAME

A) PREFACE

- I) Installation Instructions for Typical Construction
 - a) These instructions were developed and tested for use with typical construction in a wall system designed to manage water. **These instructions are not to be used with any other construction method.** Building designs, construction methods, building materials, and site conditions are unique to your project and may require an installation method different from these instructions and additional care. Determining the appropriate installation method is the responsibility of the installer, general contractor, envelope engineer and/or architect. VPI Quality Windows shall not be responsible for site conditions or any variations to these installation instructions.
 - b)  Please follow the latest version of ASTM E 2112 Standard Practices for Installation.
- II) Handling and Storage
 - a) Provide full support under the framework while storing, moving and installing the product.
 - b)  **DO NOT** lift the product by the head member only or pull from the jamb members.
 - c)  **DO NOT** store in direct sunlight or in containers without adequate ventilation. Allow sufficient spacing between products for ventilation.
 - d)  **DO NOT** lean windows more than 10 degrees or in precarious angles. Keep stored in a vertical position if possible.
 - e) Damage caused to the any part of the window or its components from poor storage practices shall not be covered under the limited warranty.
 - f)  **Due to the size and weight, a minimum of two people are required for installation.**

B) TOOLS AND MATERIALS

- I) You will need to supply
 - a) Shims/Spacers
 - b) Project approved sealants and backer rod
 - c) #8 X 1" - 2" Pan head corrosion resistant screws or other approved fasteners
- II) Tools required



- a) Tape measure
- b) 2,4 and 6 foot Level
- c) Square
- d) Hammer
- e) Flat pry bar
- f) Sealant gun
- g) Drill
- h) #2 Phillips bit drive

C) ROUGH OPENING PREPERATION

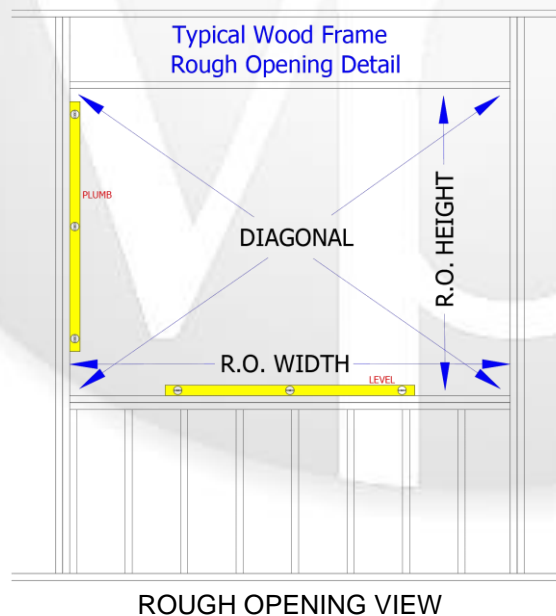

- I) Confirm the opening is plumb and level.
 - a) Ensure the sill of the rough opening does not slope toward the interior.
 - b)  It is critical the sill is level and supported without any interferences that will cause the window frame to twist, bow or tilt.
- II) Confirm the window will fit the opening.
 - a) Measure all four sides of the finished rough opening to make sure there is a minimum of 1/2" clearance in width and height. Windows that will be installed with straps require 1" clearance in width and height. The finished rough opening includes materials such as WRB, flashing, shims and any other materials that may impede the opening. Measure the width at the top, bottom, and center. Measure the height at the far left side, the far right side, and in the center. The finished RO must be a minimum of 1/2" wider and taller than the net window frame size.



- III) Sill-Pans
 - a) Sill-Pans must not interfere with proper sill support and fastening of the window unit or cause distortion to the window sill. It is the responsibility of the installer and/or general contractor to ensure that no distortion, warping or bowing is caused to the unit due to fastening over uneven surfaces. VPI requires all units be installed in a flat vertical plane.

- b)  Ensure all waterproofing materials are designed for use with PVC products and installed correctly.
- c)  VPI Quality Windows does not endorse or discourage the use of any brand of flashing or sealant materials. Following the flashing manufacturer's recommendations, apply flashing to the sills and surrounding wall surface starting with the bottom, sides and top, creating a shingle effect.

D) UNIT PREPARATION

- I) Remove shipping protection.
 - a) Unscrew the 2x4 and inspect the frame and panels for damage.
 - b)  DO NOT install damaged units.
- II) Rotate straps. (When applicable)
 - a) Rotate straps to the desired installation prior to inserting the unit into the rough opening.
 - b)  DO NOT bend or twist straps.

E) INSTALLATION STANDARDS

- I) Inspection Guidelines
 - a) Reference ASTM E2112 Standard Practice for Installation of Exterior Windows, Doors and Skylights.
 - b) Accurate measurements are essential in determining level and plumb. Measure the farthest gap between the level or string and the surface.
 - c) Use the appropriate size level to cover the maximum surface.
 - d) Use Squaring Rods for the most accurate measurement.
- II) Installation Tolerances
 - a) Square
 - i) Use squaring rods or a tape measure to measure the frame/ sash from top left to bottom right corner and from top right to bottom left corner (measure only the actual frame, do not include any applied trims.) The maximum allowable difference between measurements for windows over 20 square feet is 1/8" and windows greater than 20 square feet is 1/4".
 - b) Plumb and Level

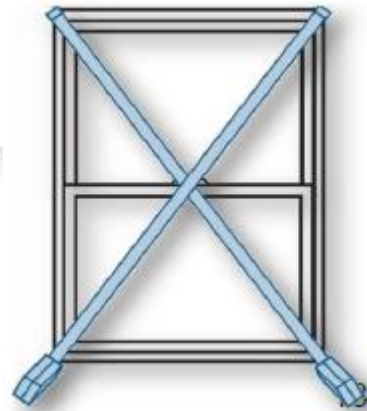

- i) For plumb and level measurements place the level against each side. Use gap gages to show the difference to level or plumb.

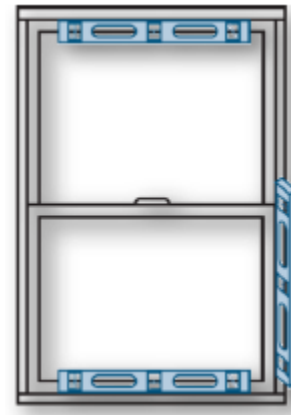

Measurement	in./ft.	Over 4 ft. in.	Max Deviation	Method of Measure
Level (horizontal measure)	1/32 in. (0.8 mm)	1/8 in. (3 mm)	1/8 in. (3 mm)	level and steel rule or tape
Plumb (vertical measure)	1/32 in. (0.8 mm)	1/8 in. (3 mm)	1/8 in. (3 mm)	level or plumb-line and steel rule or tape

c) Frame Twists

- i) Attach two pieces of string to frame/ sash, corner to corner. If the strings touch, reverse the orientation of the strings and recheck the measurements. Use gap gages to show the difference to level or plumb.

Measurement	in./ft.	Over 4 ft. in.	Max Deviation	Method of Measure
True/Rack	1/32 in. (0.8 mm)	1/8 in. (3mm)	3/16 in. (1.6 mm)	using two strings across corners

d) Frame/Panel Bow

- i) Inspect interior and exterior frame jambs, or stiles/rails of panel (not glass) to determine if bowed. Use a string slightly longer than height of frame or panel. Stretch the string over the upper and lower corners of jambs, or, stiles or rails of panel. Look for gap between string and frame or panel. If gap measures more than 1/4" at any point, the panel is bowed.

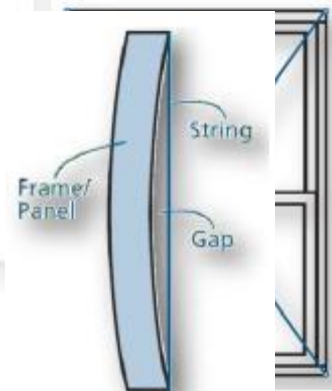

F) INSTALL AND FASTEN

- i) + Two or more people will be required for the following steps.
 - a) Shim thickness and material

b) Wedge shaped shims are not recommended for use under the sill unless used as part of an engineered sill pan system. Shims must be constructed from high impact non-deteriorating and corrosion resistant material such as PVC or similar plastic.

II) Sill shimming

a) Sill shimming should only be used when the water proofing details require it or the sill is uneven or not level. Fully supported sills without shims are preferred. However, if you choose to use shims, we require the sill to be fully supported with no gaps exceeding two inches and shims within 1/2" from any welded corners.

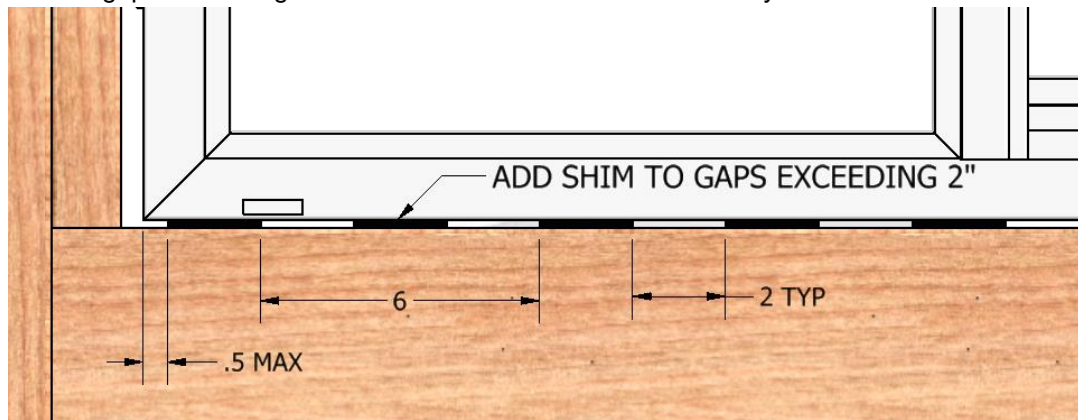

SILL VIEW

III) Insert the window

a) Insert the window by placing the sill of the window on the sill of the RO and then tilt the top into position. Center the window between the sides of the opening to allow equal clearance for shimming, temporarily fasten a few straps or insert a couple of screws to hold the window in place while shimming it plumb, level and square.

IV) Jamb shimming

a) Shims should be installed on both frame jambs and where structural horizontal members intersect the perimeter frame, and at locking hardware points.

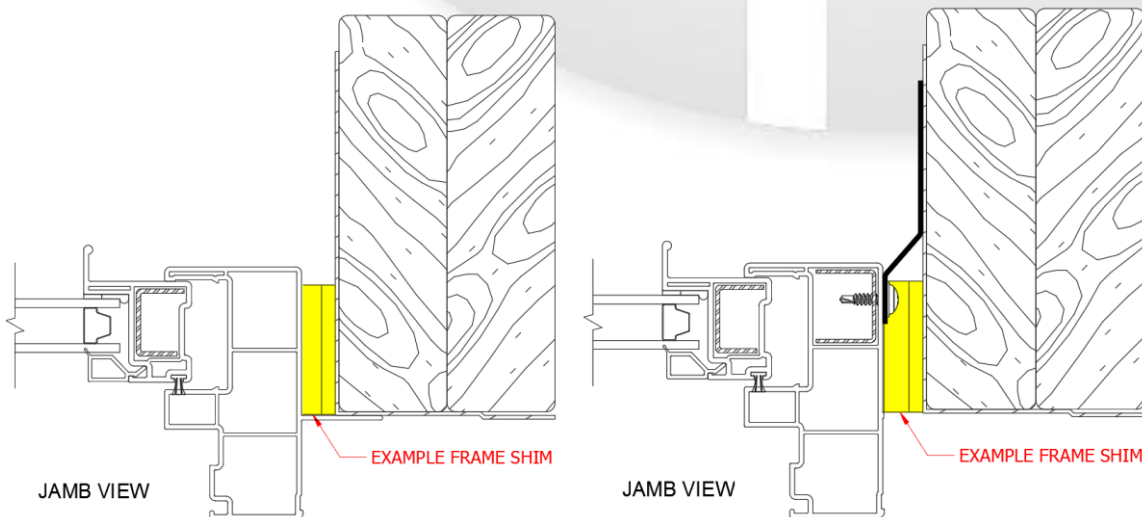

- b)  Additional shims may be required for support and squaring at the top of the jambs. It is the installers' responsibility to address any rough opening framing issues during installation.

- V)  Do not shim head
 - a) Shimming the head will not allow for normal building movement and will cause failures that are not warrantable.

- VI) Plumb and square the window
 - a) Insert shims between the window and rough opening. Keep shims back 1/4" from interior face of window if interior seal is specified. The window must be plumb, level and square to avoid having unnecessary adjustments to the sash panel.
 - b)  Shims must be verified before fastening.

- VII) Frame Squaring
 - a) **Frame Squaring** is essential. To do this properly one must first take corner to corner dimensions (D1 & D2) then determine if both dimensions are within the allowed 1/8" of tolerance. If not then split the difference and that is the overall adjustment that needs to be made.
 - b) **Level & Plumb** Use a level to check the sill and jamb to determine if the frame is level and plumb.

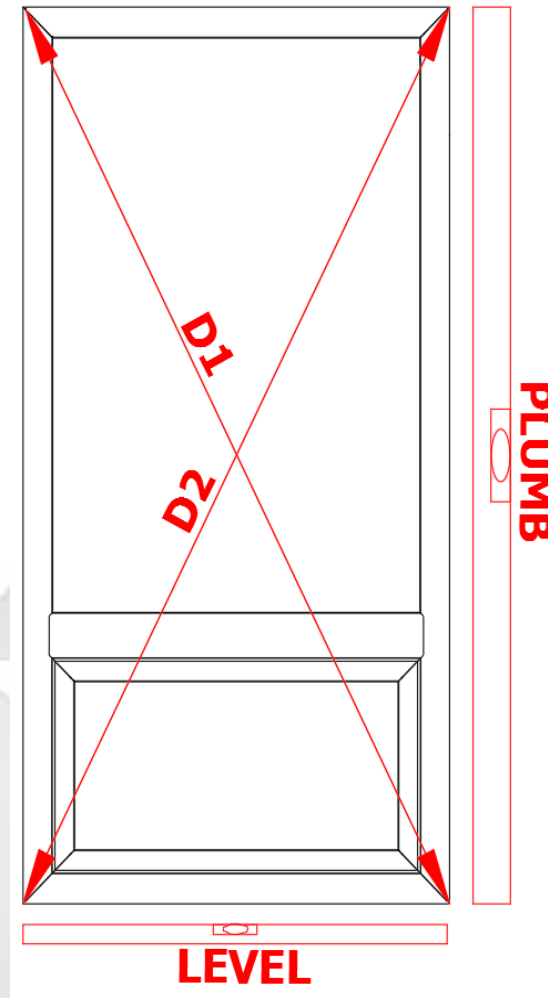

- VIII) Fastening the window to the opening
 - a) For straps - use specified fasteners into every hole of every strap. Shims are required behind the strap to prevent the strap from twisting the frame and support for each screw.

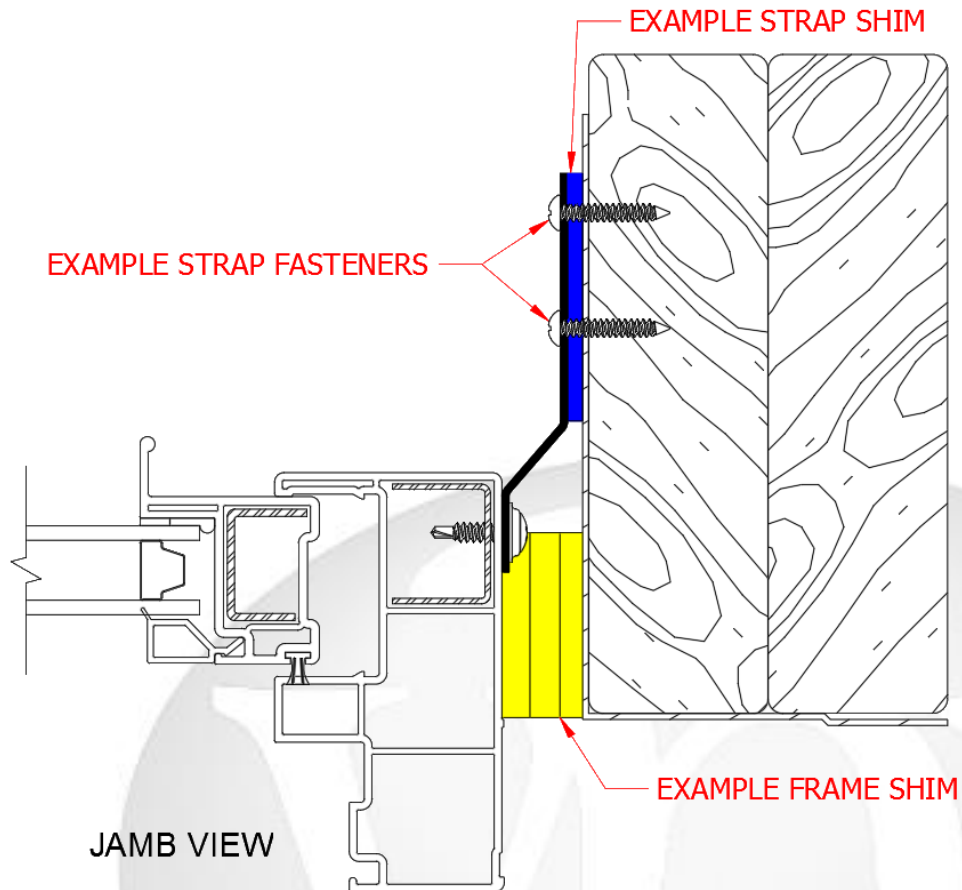

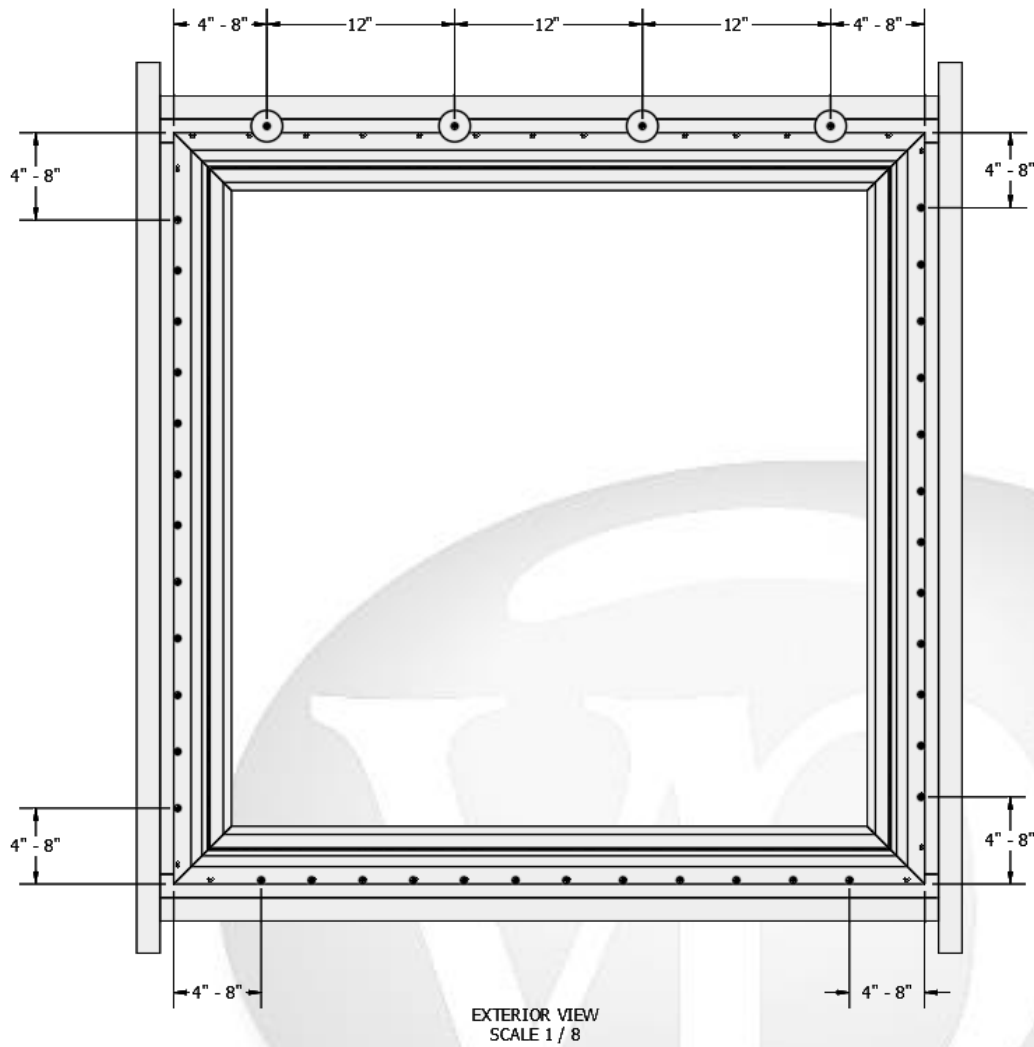

- IX) For nail fin – use specified fasteners.
- a) Head must be fastened, beginning 4" – 8" from welded corners, then every 12" on center using fender washers lapped over nailing flange a minimum of 3/8", leaving a minimum of 3/8" gap between shaft of fastener and edge of nailing flange.
 - b) Fastener size is #8 and must penetrate structural framing a minimum of 1" in depth and must be constructed of corrosion resistant material such as stainless steel, galvanized or other coating.
 - c) Place fasteners in every hole of the nail flange along jamb and sill beginning 4"-8" from welded corners. (See Illustration on next page.)

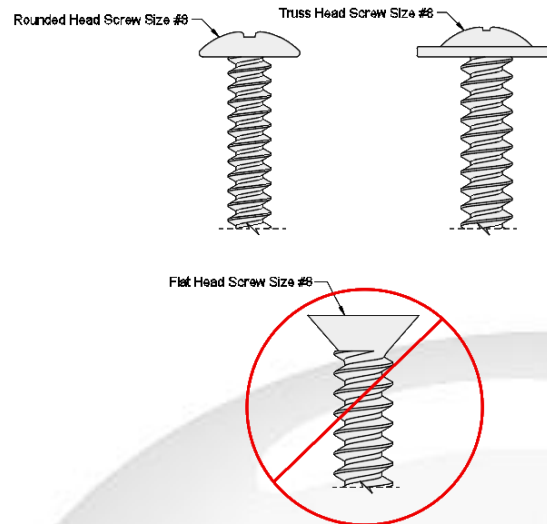

- ❖ **NOTE:** When straps are present only at T-Bar / frame intersections it is required to use the nail fin for fastening. When nail fin and straps are both present it is not required to use the nail fin for fastening.

- d)  **All fasteners** must have a rounded head and be constructed from or coated with corrosion resistant material such as, but not limited to stainless or galvanized steel. Screws must penetrate a minimum of 1" into structural framing.



- e)  Vinyl windows and doors require shimming and fastening to support the frame from twisting and moving. Shim behind straps to avoid frame roll.

FRAME ROLL CAUSED BY INSUFFICIENT SHIMMING WILL CAUSE OVER & UNDER COMPRESSION OF THE FRAME AND SASH AND COULD POTENTIALLY DAMAGE THE GASKETS, WEATHERSTRIPPING OR LOCKING HARDWARE.

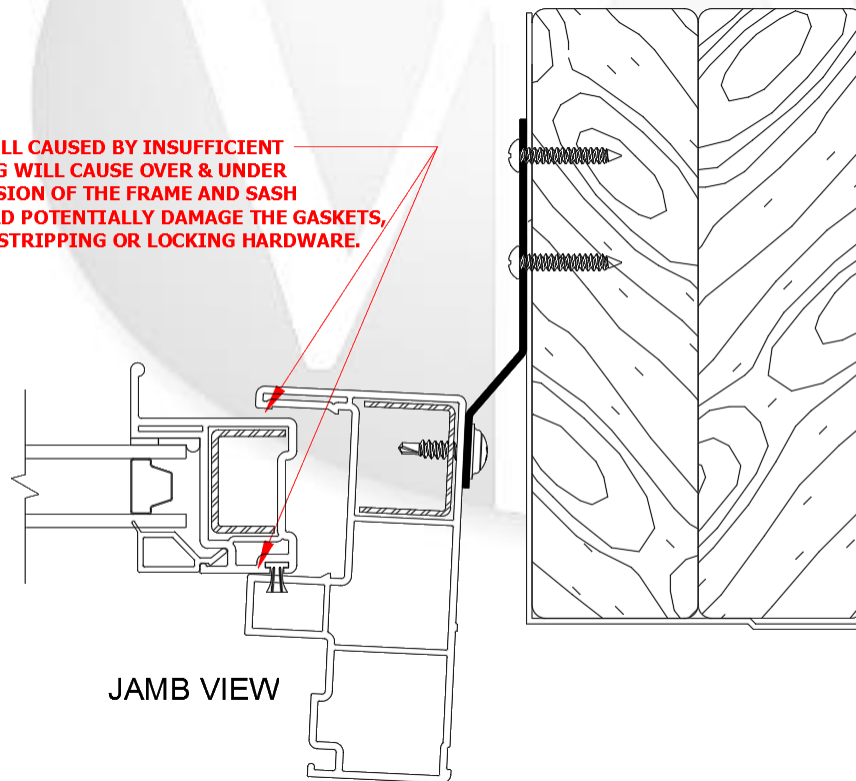

- f)  **DO NOT** over tighten as this may distort or twist the frame.

- X) Verify sash weatherstrip is engaging frame.
 - a) This can simply be done by observing from the exterior side of the sash and the frame when closed and locked. From the interior you can measure the frame to sash. VPI has a 1/16" plus or minus tolerance for the dimensions referenced below. (See dimensional references below)

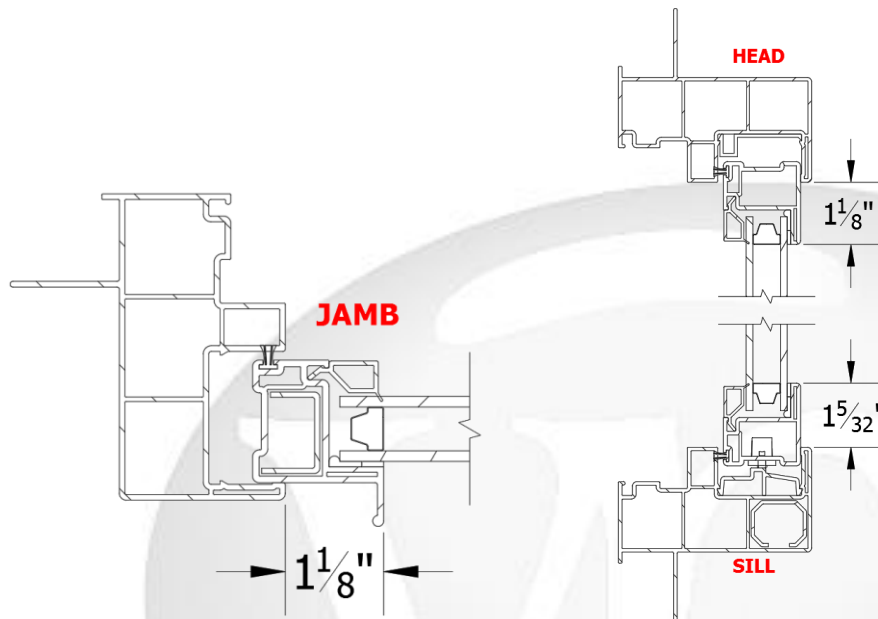

- b) The affected area of compression loss or gain will need to be shimmed behind the frame in order to correct the frame roll. Refer to Sections 5.4 & 5.5 for any remedial work that may need to be done to correct frame roll.
- c)  This must be done before finalizing the install, check both interior and exterior.

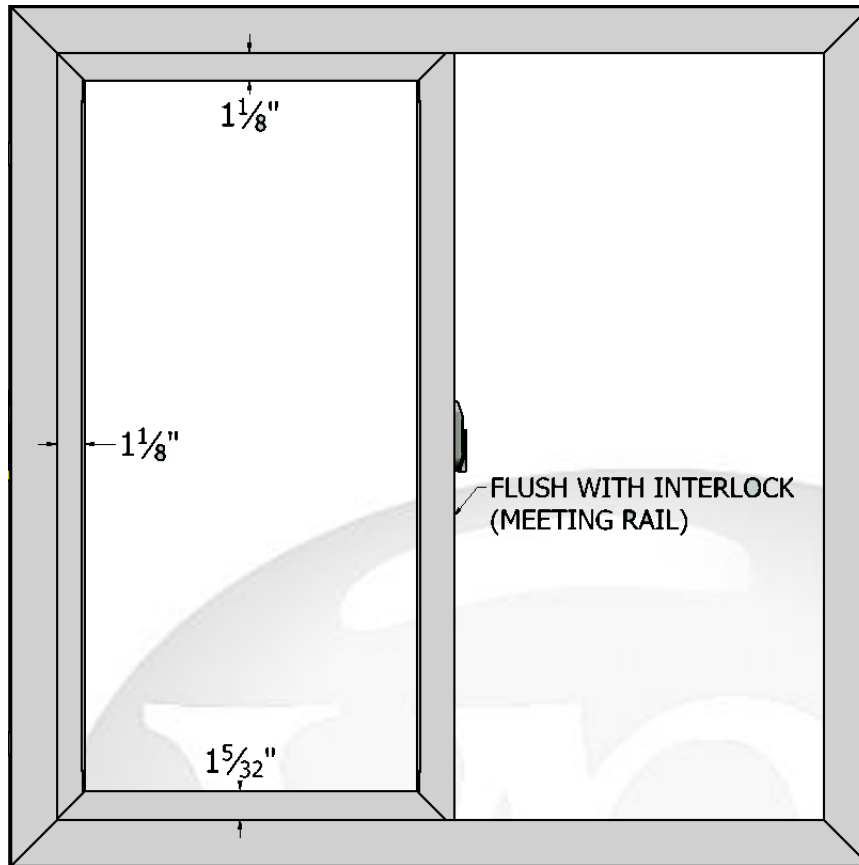

G) FINAL ADJUSTMENT

- I) Slider or Single Hung windows (530-591 series) have no final adjustments needed.
- II) Verify the reveal is consistent on the operable panel to the frame. (See illustration on next page.)



INTERIOR REVEAL VIEW

III) Operate the sash panel and verify the sash freely opens, closes and locks properly.

- a)  Verify all locking points on the window are engaging before finalizing the installation.
- b)  It is the responsibility of the installer to verify the window operates and locks correctly; adjustments are required by the installation company to finalize the install. Follow ASTM E 2112 Standard Practices for Installation. Please contact VPI for any assistance or training with our product @ 1-800-634-1478

Part 2) DEEP BACKSET 6" FRAME

A) PREFACE

I) The Deep Backset Frame installs like the standard 531/591 frame. Guidelines stated above still apply. This section was created to show details of installing scenarios specific to the Deep Backset Frame.

II) 6" Deep Backset Frame shown in 3 nail fin positions; 1", 1.375" and 3.875"

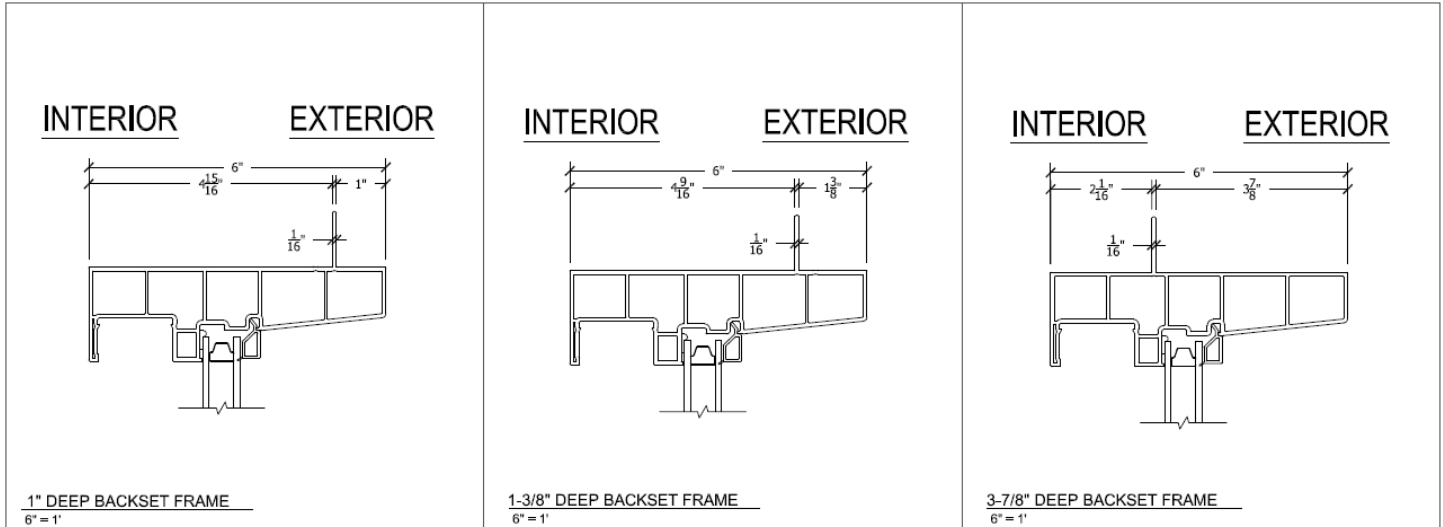

III) Below are details shown for the three nail fin positions available as well as a no fin option.

- a) There are 3 scenarios each for the Head, Jam and Sill. These are; nail fin inside of insulating foam board, nail fin outside of insulating foam board and installing with no foam board on the exterior.
- b) Each scenario shows install methods using the nail fin or Steel and Strap.

B) NAIL FIN 1" BACKSET FROM EXTERIOR FACE DETAILS

I) Head

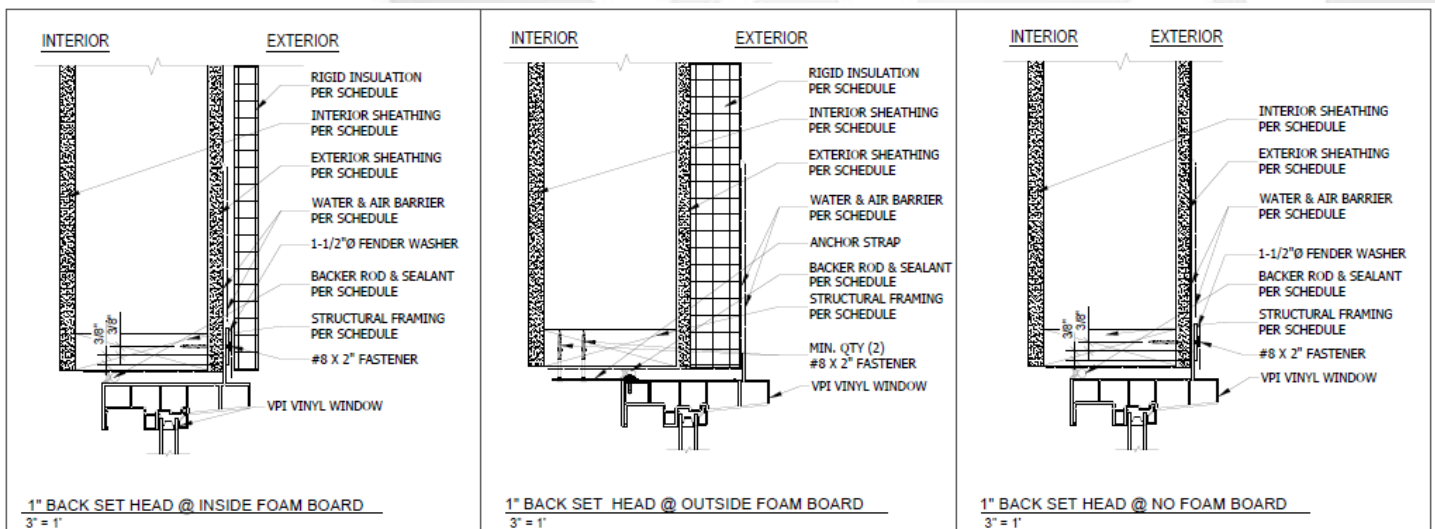

- II) Jam
- III) Sill

C) NAIL FIN 1.375" BACKSET FROM EXTERIOR FACE DETAILS

- I) Head

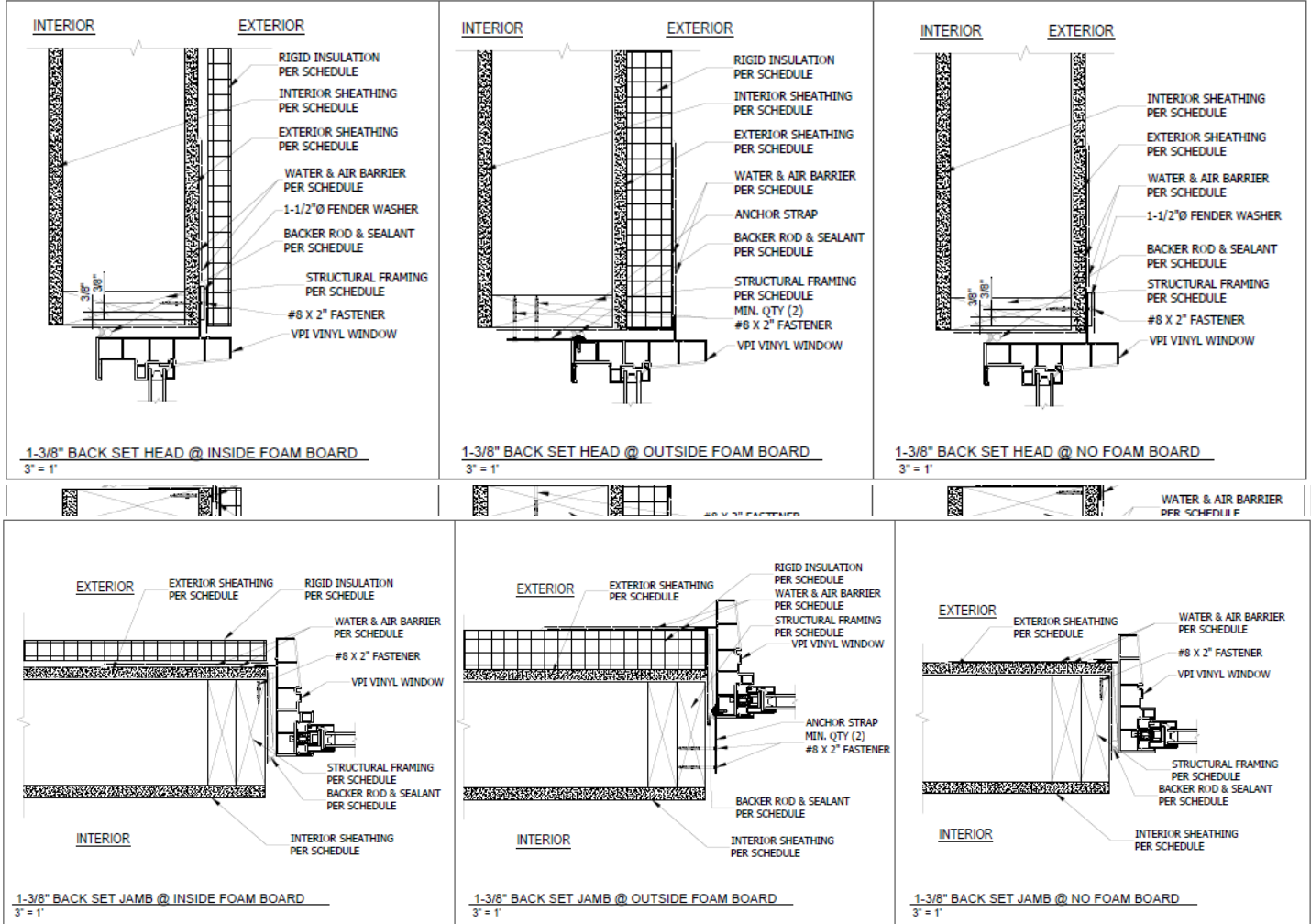

- II) Jam

III) Sill

D) NAIL FIN 3.875" BACKSET FROM EXTERIOR FACE DETAILS

I) For the 3.875" nail fin position, nailing flange must be fastened against exterior sheathing behind any exterior elements such as rigid insulation and masonry. Window must be supported by structural framing.

II) Head

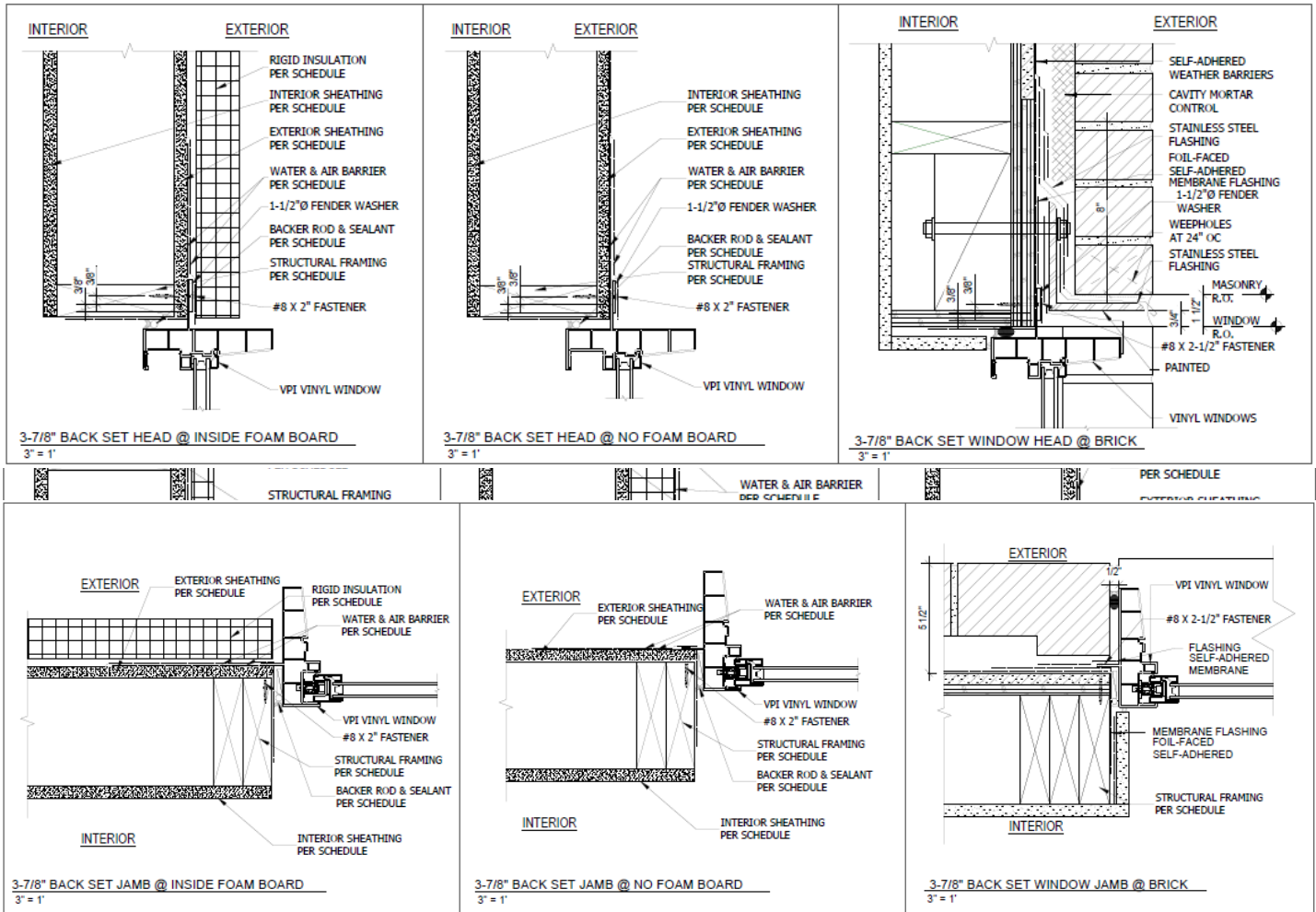

III) Jam

IV) Sill

E) NO FIN

- I) Strap anchors may be used with or without nailing flanges, however the nailing flange location determines proper depth. Follow depth instructions in Part 2 subsection D.
- II) Head

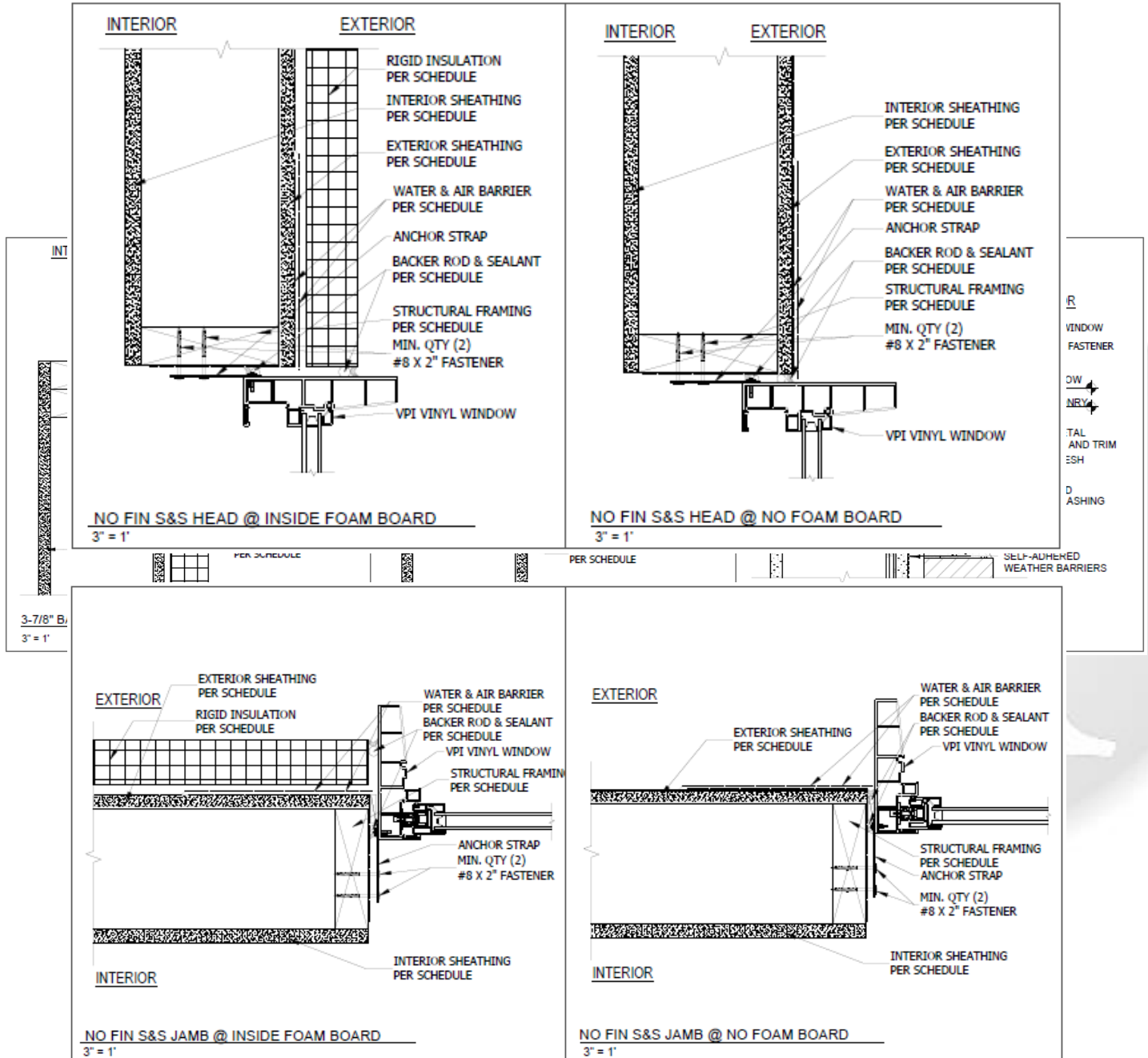

III) Jam

IV) Head

