

DETAIL C
SCALE 1 / 2

HP INTERIOR SILL ADAPTER
INCLUDED WITH ALL INSWING DOORS;
OPTIONAL WITH OUTSWING DOORS.

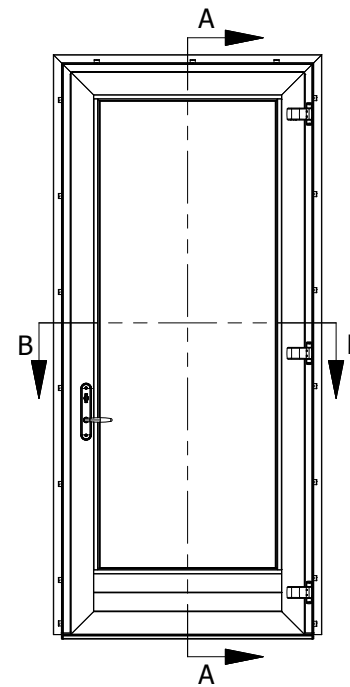

INTERIOR
SCALE 1/32



JAMB
SCALE 1/32

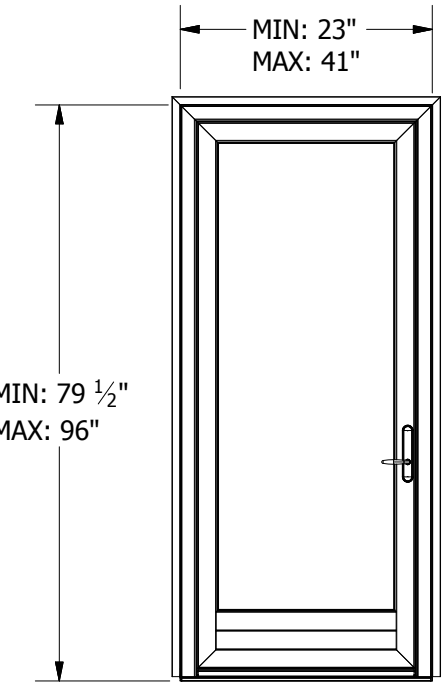

EXTERIOR
SCALE 1/32

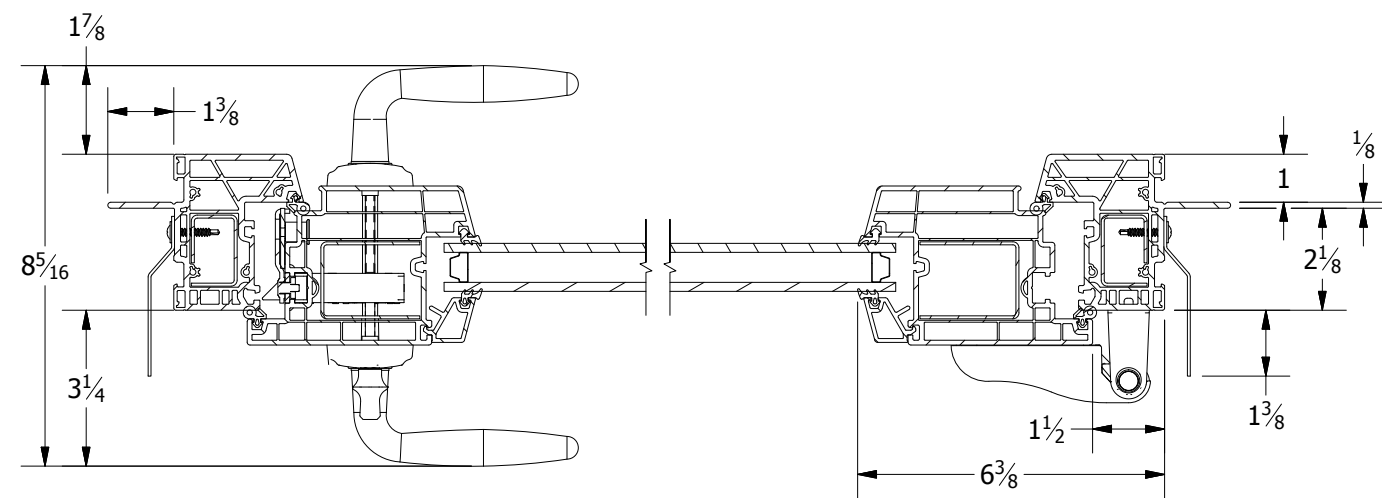

TOLERANCE DECIMAL X.X ± 0.100 X.XX ± 0.025 X.XXX ± 0.005 FRACTIONAL X/X ± 1/32 ANGULAR X ± 1.0° X.X ± 0.2°	DRAWN	bpoutre	12/18/2019		
	CHECKED				
	APPROVED				
	SIZE	B	SCALE	1/32	SHEET
PRODUCT FAMILY	1200 ENVISION				
PROJECT					



3420 E Ferry Ave. Spokane, WA 99202 • www.vpiwindows.com
THIS DOCUMENT IS PROPRIETARY AND CONFIDENTIAL. NO PART OF THIS DOCUMENT MAY BE DISCLOSED IN ANY MANNER TO A THIRD PARTY WITHOUT THE PRIOR WRITTEN CONSENT BY VPI QUALITY WINDOWS.

SHEET
HLIS_HP W/KP LAYOUT

REV
B