

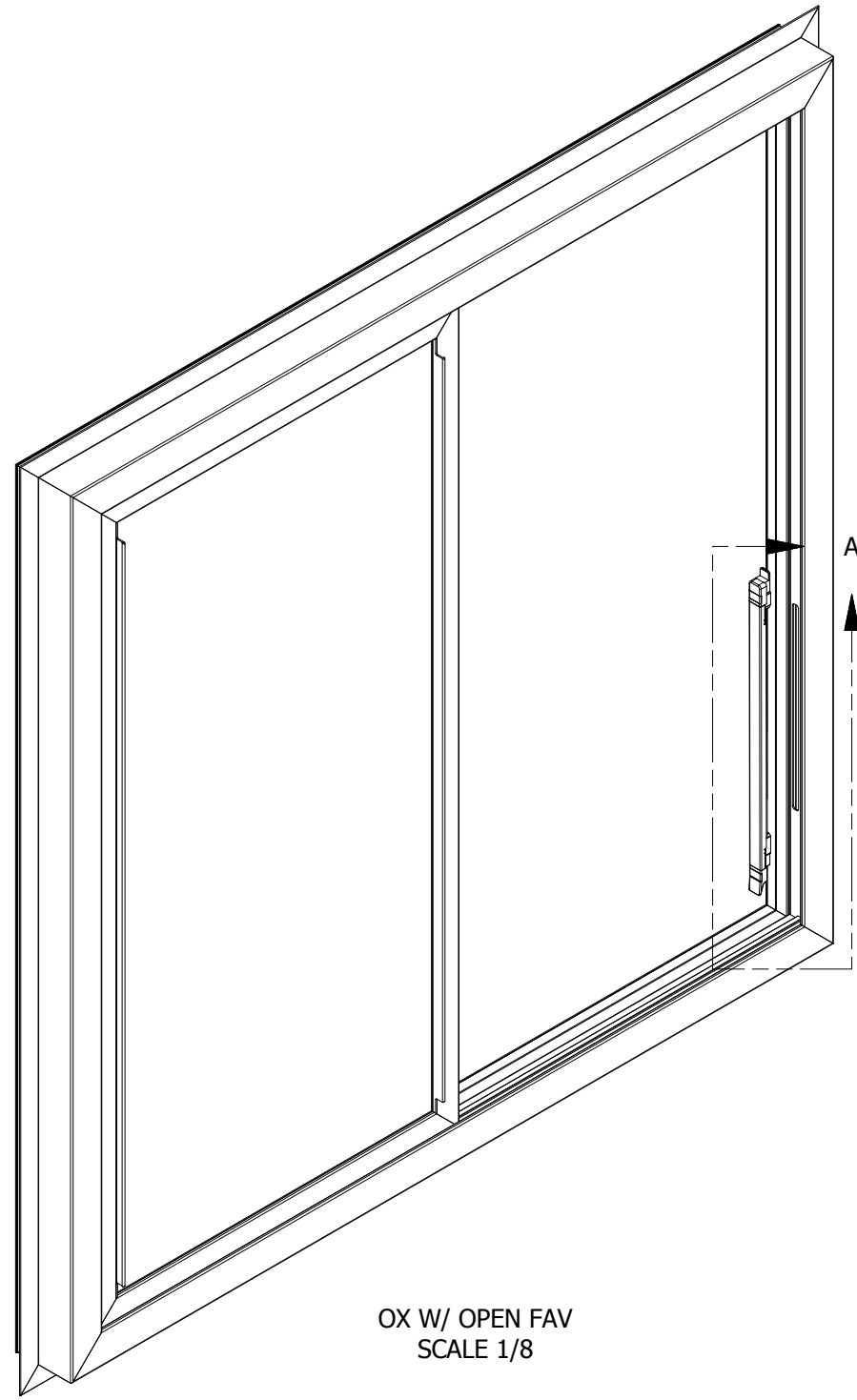

DETAIL A  
SCALE 1 / 2



OX W/ OPEN FAV  
SCALE 1/8

<b>TOLERANCE</b> DECIMAL X.X ± 0.100 X.XX ± 0.025 X.XXX ± 0.005 FRACTIONAL X/X ± 1/32 ANGULAR X ± 1.0° X.X ± 0.2°	DRAWN bpoutre	8/11/2017	
	CHECKED		
	APPROVED		
	SIZE B SCALE 1/8 SHEET 1 of 5		
PRODUCT FAMILY <b>530 - 591 ENDURANCE</b>	<b>3420 E Ferry Ave. Spokane, WA 99202 ● www.vpiwindows.com</b>		THIS DOCUMENT IS PROPRIETARY AND CONFIDENTIAL. NO PART OF THIS DOCUMENT MAY BE DISCLOSED IN ANY MANNER TO A THIRD PARTY WITHOUT THE PRIOR WRITTEN CONSENT BY VPI QUALITY WINDOWS.
PROJECT	SHEET 531 OX W/ OPEN FAV	REV	

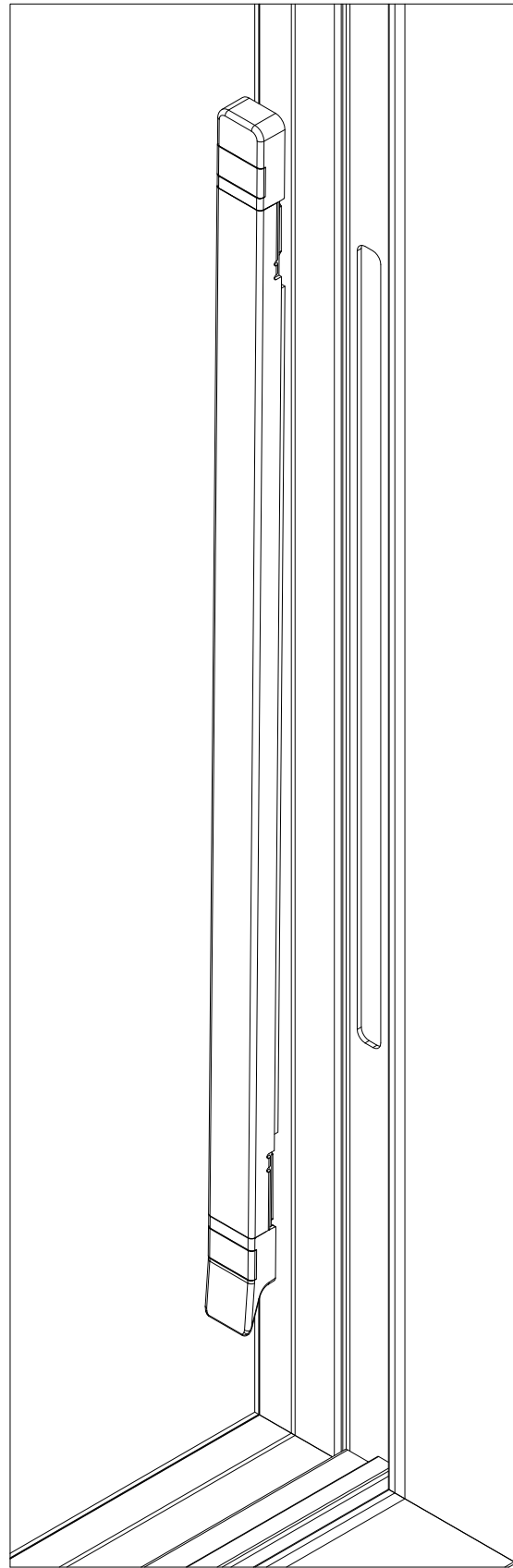

DETAIL A  
SCALE 1 / 2

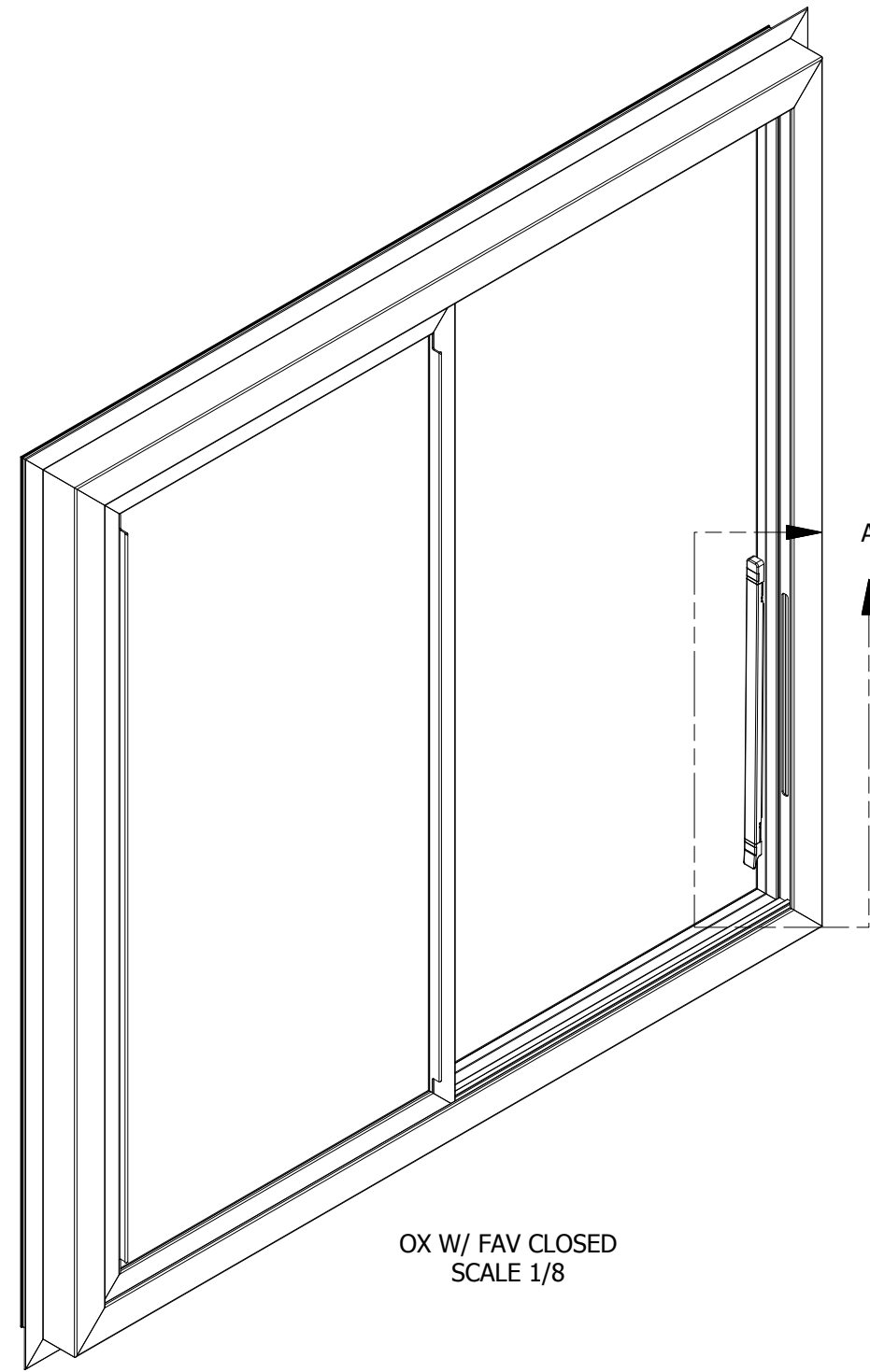

OX W/ FAV CLOSED  
SCALE 1/8

<b>TOLERANCE</b> DECIMAL X.X ± 0.100 X.XX ± 0.025 X.XXX ± 0.005 FRACTIONAL X/X ± 1/32 ANGULAR X ± 1.0° X.X ± 0.2°	DRAWN	8/11/2017			
	CHECKED				
	APPROVED				
	SIZE	B	SCALE	1/8	SHEET
PRODUCT FAMILY	530 - 591 ENDURANCE				
PROJECT					



3420 E Ferry Ave. Spokane, WA 99202 • www.vpiwindows.com  
THIS DOCUMENT IS PROPRIETARY AND CONFIDENTIAL. NO PART OF THIS DOCUMENT MAY BE DISCLOSED IN ANY MANNER TO A THIRD PARTY WITHOUT THE PRIOR WRITTEN CONSENT BY VPI QUALITY WINDOWS.

SHEET	REV
531 OX W/CLOSED FAV	

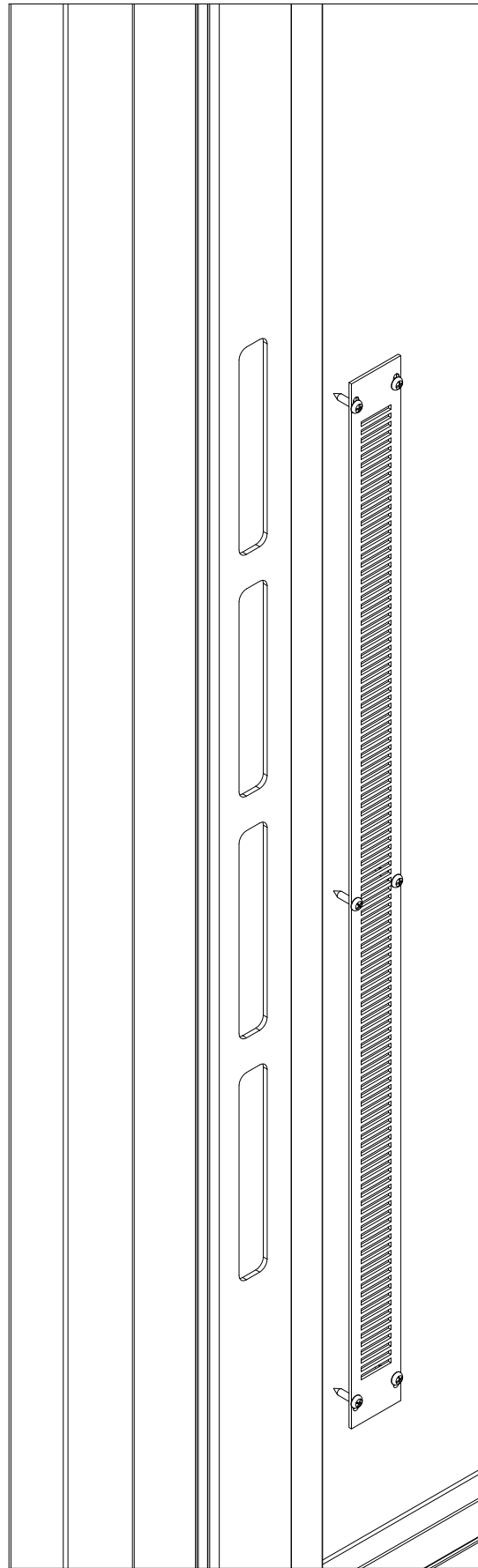

DETAIL A  
SCALE 1 / 2

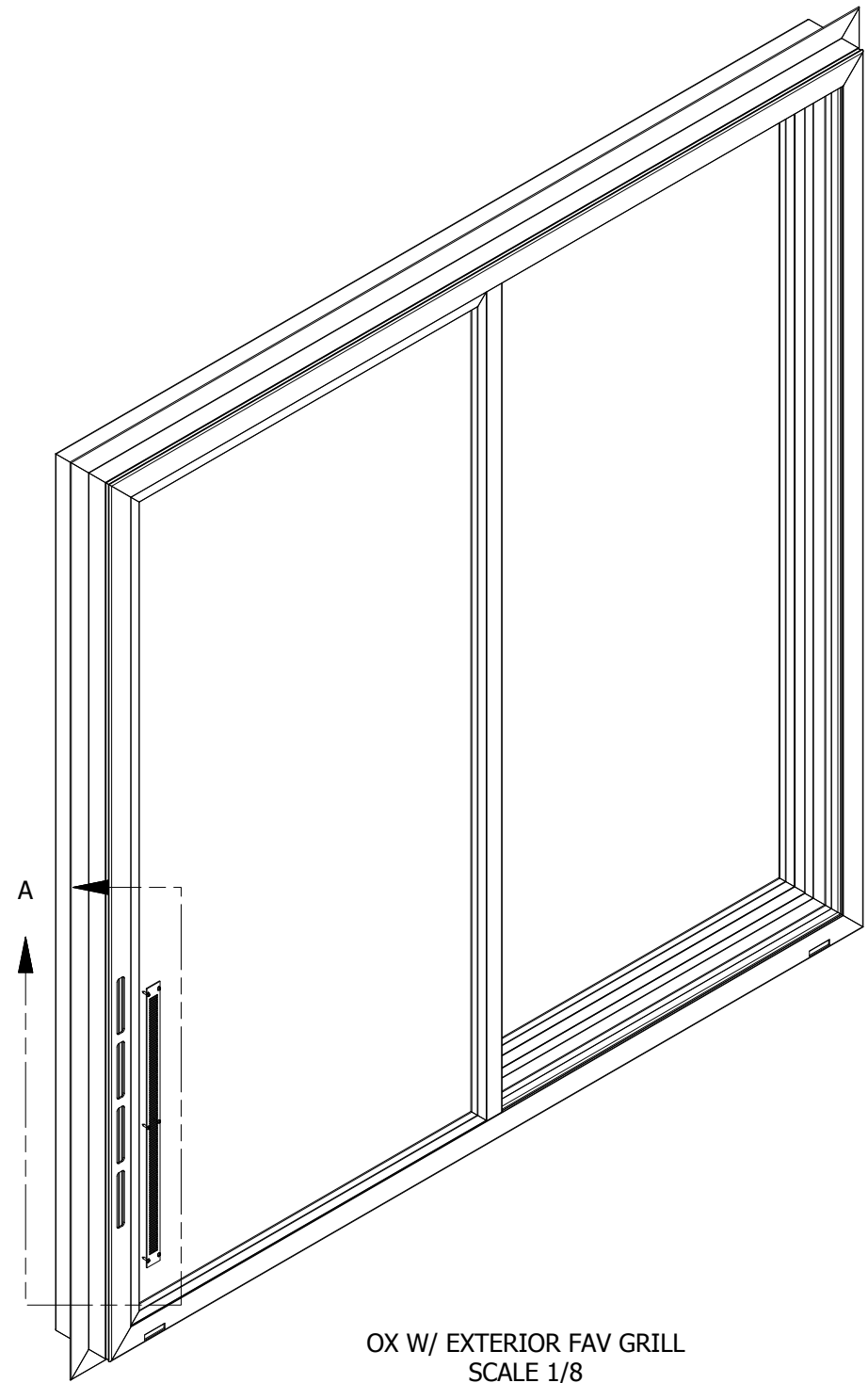

OX W/ EXTERIOR FAV GRILL  
SCALE 1/8

<b>TOLERANCE</b> DECIMAL X.X ± 0.100 X.XX ± 0.025 X.XXX ± 0.005 FRACTIONAL X/X ± 1/32 ANGULAR X ± 1.0° X.X ± 0.2°	DRAWN bpoutre	8/11/2017	
	CHECKED		
	APPROVED		
	SIZE B SCALE 1/8 SHEET 3 of 5		
PRODUCT FAMILY <b>530 - 591 ENDURANCE</b>	<b>3420 E Ferry Ave. Spokane, WA 99202 • www.vpiwindows.com</b> <small>THIS DOCUMENT IS PROPRIETARY AND CONFIDENTIAL. NO PART OF THIS DOCUMENT MAY BE DISCLOSED IN ANY MANNER TO A THIRD PARTY WITHOUT THE PRIOR WRITTEN CONSENT BY VPI QUALITY WINDOWS.</small>		
PROJECT	SHEET 531 OX W/ EXTERIOR FAV GRILL	REV	

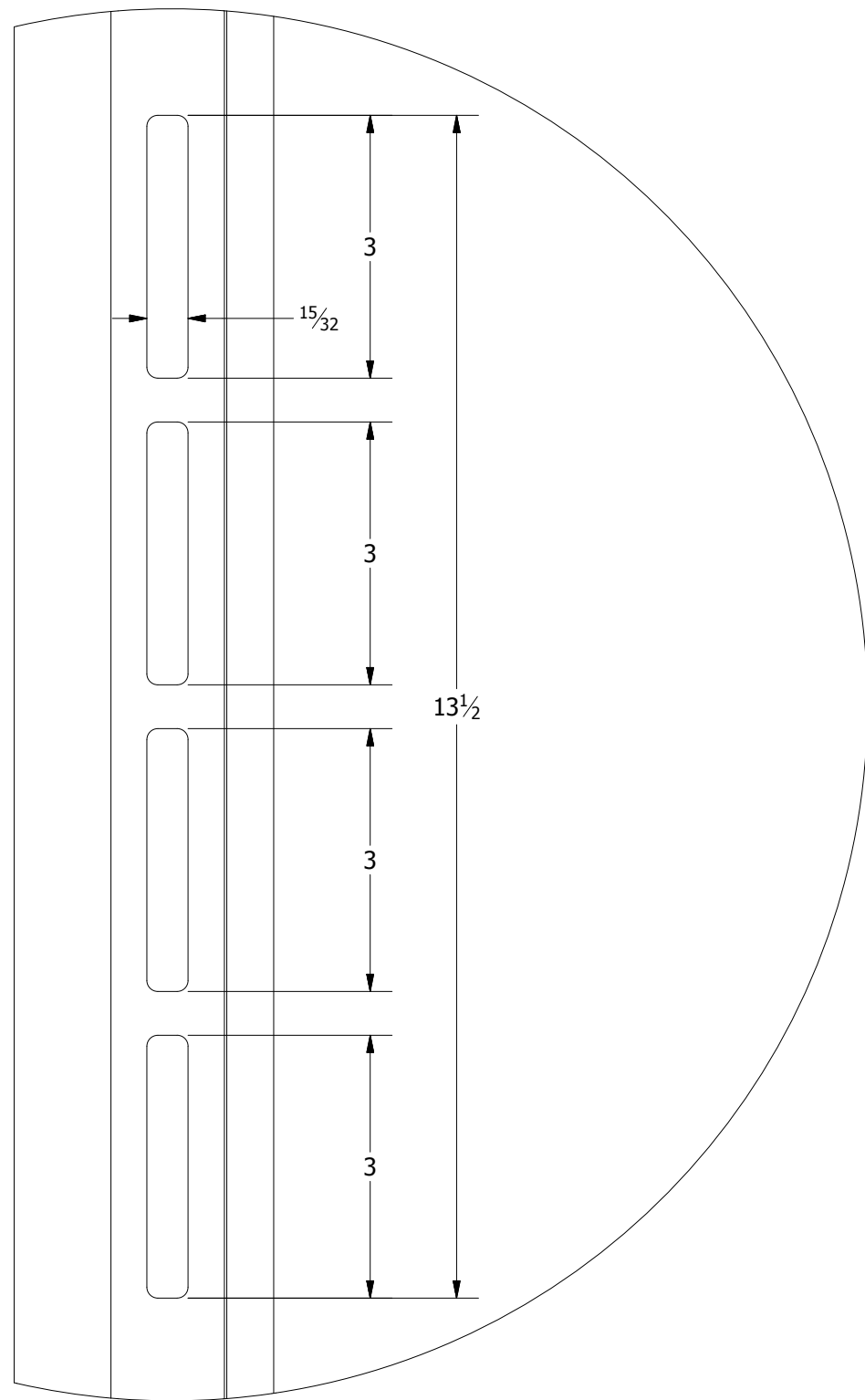

DETAIL A  
SCALE 1 / 2

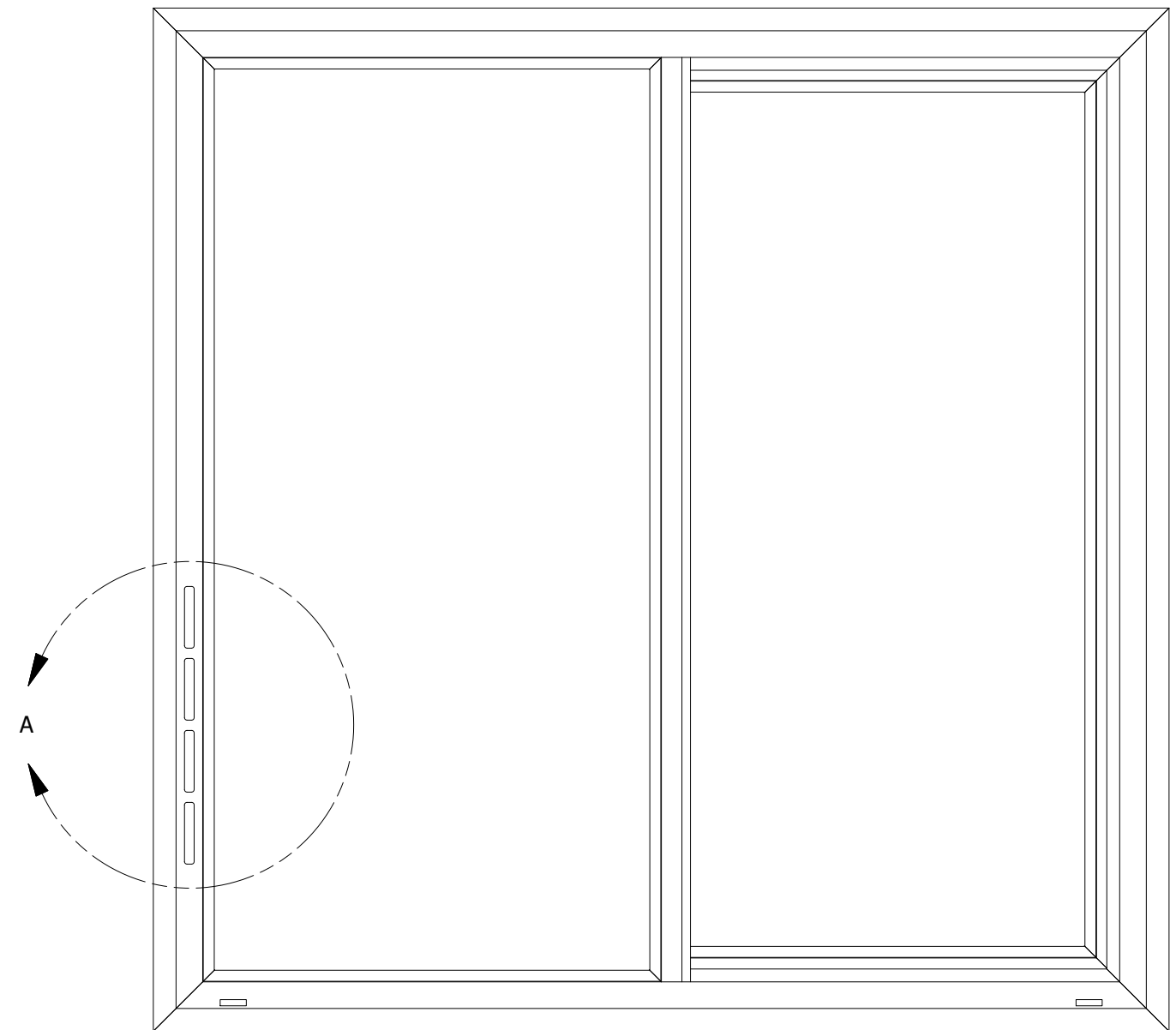

EXTERIOR FAV FABRICATION  
SCALE 1/8

<b>TOLERANCE</b> DECIMAL X.X ± 0.100 X.XX ± 0.025 X.XXX ± 0.005 FRACTIONAL X/X ± 1/32 ANGULAR X ± 1.0° X.X ± 0.2°	DRAWN	bputre		8/11/2017	
	CHECKED				
	APPROVED				
	SIZE	B	SCALE	1/8	SHEET
PRODUCT FAMILY		530 -591 ENDURANCE			
PROJECT		531 OX W/ EXTERIOR FAV FABRICATION			
				3420 E Ferry Ave. Spokane, WA 99202 ● www.vpiwindows.com THIS DOCUMENT IS PROPRIETARY AND CONFIDENTIAL. NO PART OF THIS DOCUMENT MAY BE DISCLOSED IN ANY MANNER TO A THIRD PARTY WITHOUT THE PRIOR WRITTEN CONSENT BY VPI QUALITY WINDOWS.	
				SHEET 531 OX W/ EXTERIOR FAV FABRICATION	
				REV	

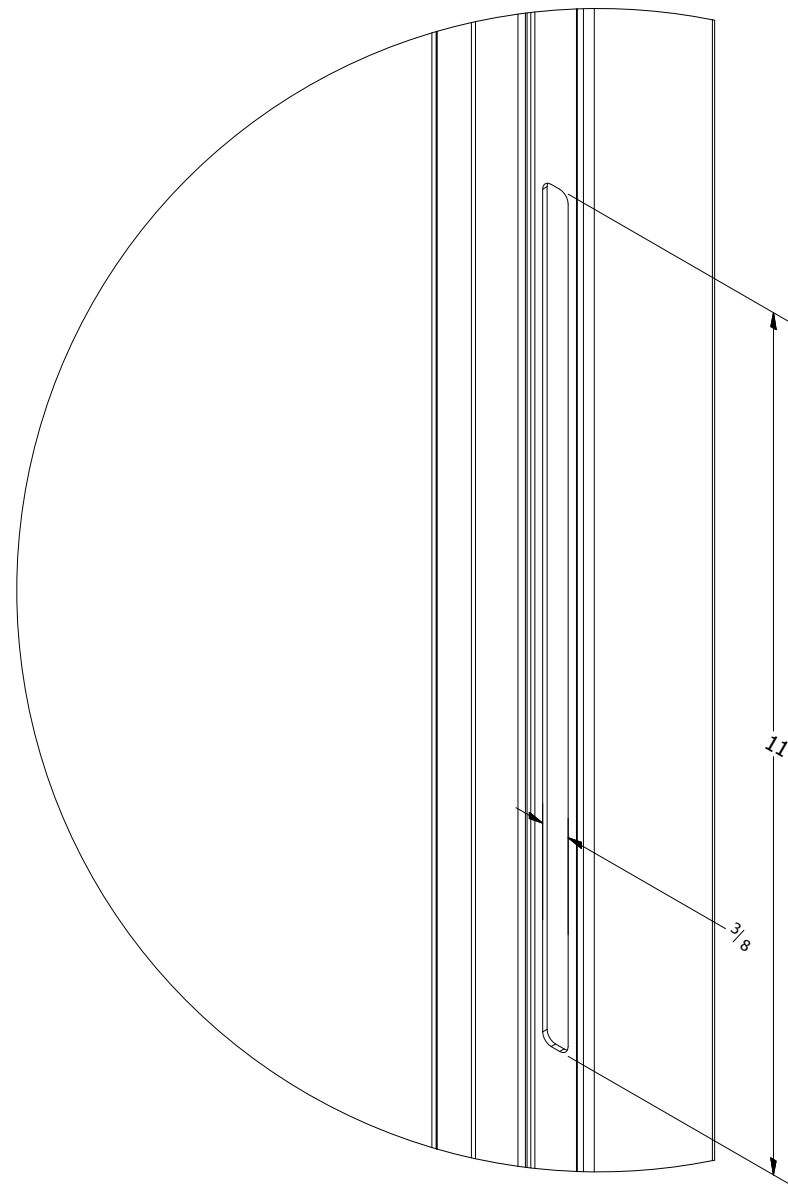

DETAIL A  
SCALE 1 / 2

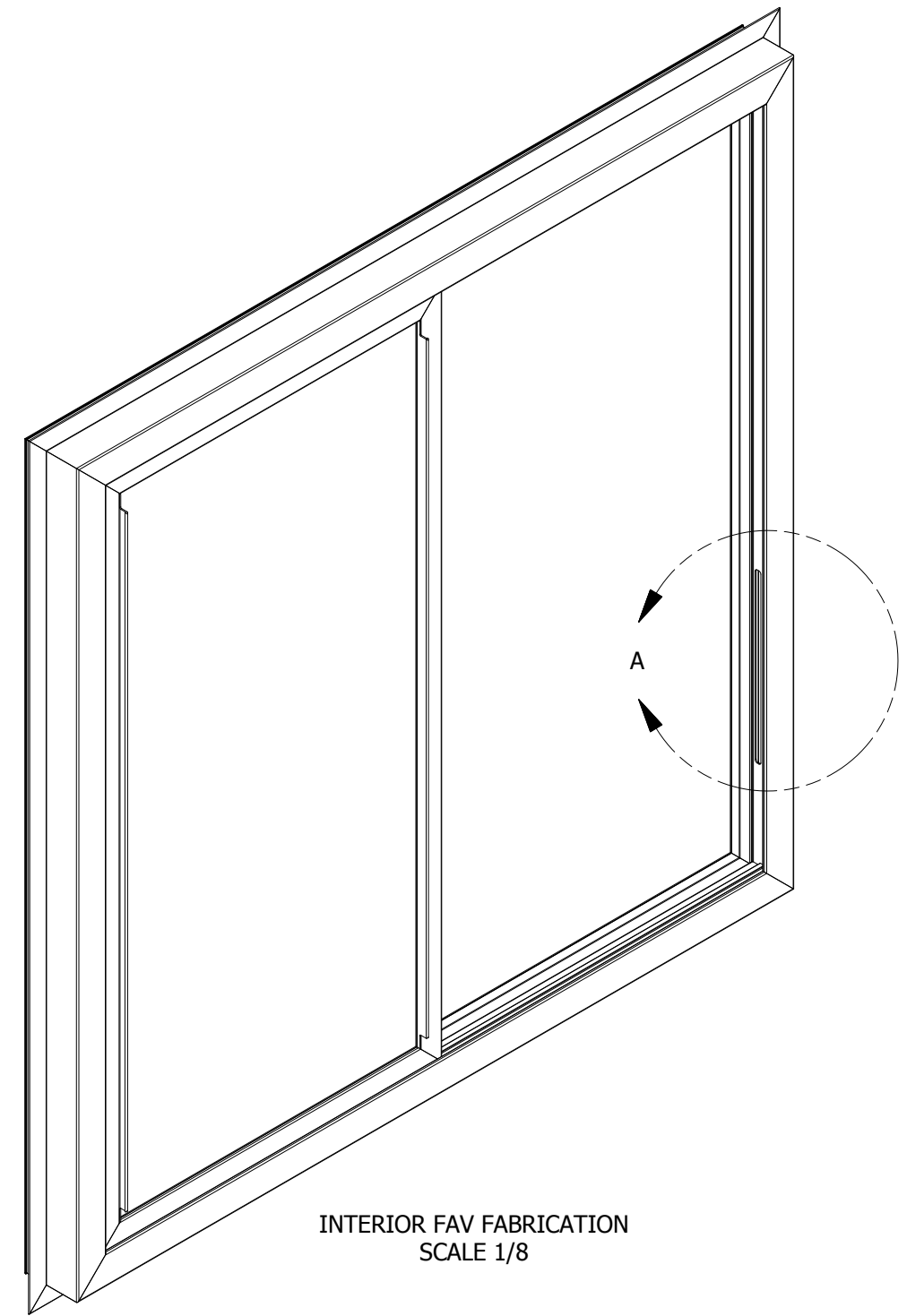

INTERIOR FAV FABRICATION  
SCALE 1/8

<b>TOLERANCE</b> <u>DECIMAL</u> X.X ± 0.100 X.XX ± 0.025 X.XXX ± 0.005 <u>FRACTIONAL</u> X/X ± 1/32 <u>ANGULAR</u> X ± 1.0' X.X ± 0.2'	DRAWN bpoutre	8/11/2017
	CHECKED	
	APPROVED	
	SIZE B SCALE 1/8 SHEET 5 of 5 PRODUCT FAMILY	
PROJECT	SHEET 531 OX W/ INTERIOR FAV FABRICATION	
		REV



3420 E Ferry Ave. Spokane, WA 99202 • www.vpiwindows.com  
 THIS DOCUMENT IS PROPRIETARY AND CONFIDENTIAL. NO PART OF THIS DOCUMENT MAY BE DISCLOSED  
 IN ANY MANNER TO A THIRD PARTY WITHOUT THE PRIOR WRITTEN CONSENT BY VPI QUALITY WINDOWS.