



FRICTION ADJUSTORS:

Friction Adjustors are used either as a limit device or for additional friction in conjunction with certain types of hinging on projected windows. By tightening a screw in the sliding brass shoe, a homeowner can easily adjust the tension required to open and close the window. When used as a Limit Device the hardware is designed to restrict the opening on projected or casement windows. This mechanism automatically stops the vent at a safety position as required by the user, or required by law. For cleaning and ease of window assembly, a key may be used to release the window to its maximum opening. See Models #37.26 through #37.34.

LIMIT DEVICES:

Two different varieties of Limit Devices are available. When properly installed and operated, the Limit Device will help prevent damage to casement and awning windows under high winds in high-rise applications. Two different methods of disconnecting the Limit Device from the sash for cleaning purposes - either by inserting a key, or by operating the detach clip.

A variety of track and arm lengths are available for this product. Consult the attached drawings to determine the correct length that will be required for the window based on the application of this product.

SUPPORT ARMS:

Designed for use on top-hung windows. Two Support Arm models are available – the first opens to full extension and automatically locks into place for ventilation or window maintenance. The second is designed to extend only 1.500” (first-position opening) under normal operating conditions for limited opening applications. This means an actual window opening of approximately 4” to 8” depending on mounting locations. A key can be inserted to release the arms to achieve its maximum-open position for window maintenance. The vent can then be locked open at this position by manually engaging a locking lever. The locking lever feature securely locks the window in the open position for

maintenance and to prevent sudden closing during wind gusts. To unlock either Support Arm from its maximum-open position, simply lift the sash slightly before closing.

The support arm with limited opening feature automatically engages back into the first-position opening when closed. For larger windows, adjustable friction is available in the #37.20 through #37.24 series which helps to stabilize the vent and prevent it from closing by its own weight or wind conditions.

MATERIAL: Friction Adjustor is non-magnetic stainless steel with nylon friction block encased in a sliding brass shoe. #99 Limit Devices are plated steel arms with stainless steel track and detach clip - or, an a non-magnetic stainless steel model is also available Support Arms are non-magnetic stainless steel.

ORDERING INFORMATION:

Friction Adjustor

1. From the information available on the following drawings – specify the correct arm and track length that will be required for your window. Reference numbers in table on next page.
2. All Heavy Duty Friction Adjustors come equipped with a .235” (5.9 mm) bracket unless otherwise specified – see Dimension A in Figure 2. Optional brackets not available for Standard

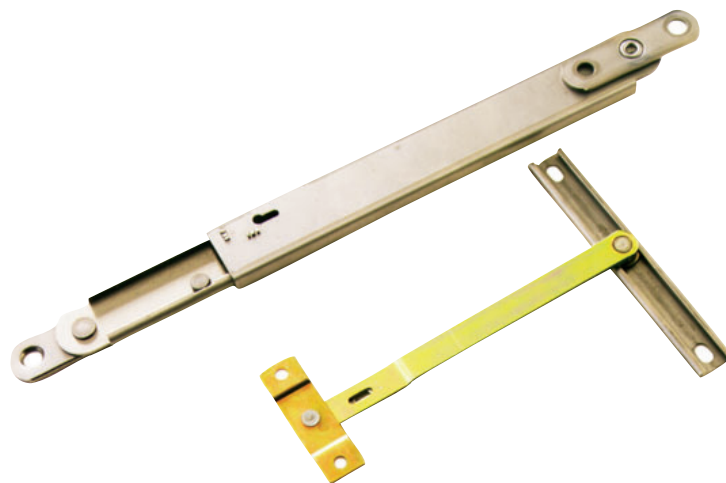

Duty Friction Adjustors.

Limit Device

1. Specify product by part number - refer to drawings for specific information.
2. Limit Device Key (#16002) sold separately — only required for #37.26 through #37.34.

Support Arms

1. Order 2 arms per vent.
2. Specify product by part number (length of hardware is measured in extended position).
3. Order Release Key (#16001) separately. Two keys required to open window for models #37.20 through 37.24.
4. These Support Arms provided without brackets. If brackets are required, please consult the tables within Support Arm drawings for the optional brackets. If brackets are ordered, a standard .015” (.4 mm) washer will be provided between the bracket and the Support Arm. To increase stack height, optional washers of .050 or .093 are available. Please specify when ordering.

RECOMMENDED SCREWS:

Types of screws required determined by material of profile used. Refer to drawings for complete information on screw type and quantity needed (sold separately).

TRUTH TIPS:

1. Truth recommends that a Friction Adjustor/Limit Device be used in any application over two stories to protect the window and hardware from excessive wind loads in the near fully open position. The degree of friction and limited opening depends on anticipated wind loads.
2. Friction Adjustors can be used either as a hold-open device or for additional friction in conjunction with some types of hinging on projected or casement sashes. The manufacturer determines for himself the placement of the unit and the correct track and arm length required to obtain whatever amount of opening is desired.
3. For accurate hardware placement in vinyl or metal applications, pre-drilling of the window profile is recommended.
4. For vinyl window applications, mounting screws should pass through two PVC walls, or one PVC wall and one insert wall. For this reason, it may be necessary to use a longer screw than is recommended.
5. For metal window profiles Truth recommends machine screws however, in most applications sheet metal screws will provide adequate holding power.
6. Support Arms should be mounted as low as possible on the sash and frame for maximum strength. The window manufacturer must determine the placement of the hardware dependent upon the amount of opening.
7. For easy correction of out of square or racked window installations, the use of Truth Jamb Jack III frame adjusters is recommended. Frame adjustment can improve both weather seal tightness and sash operation over the life of the window.

**INCLUDE TRUTH SPECS ON
YOUR NEXT WINDOW PROJECT**

Sash control devices as required by "life safety" codes. Friction adjustment features to be provided which allow fine tuning of sash motion.

Sash control devices of 37/99 series, as manufactured by Truth Hardware.

HEAVY DUTY FRICTION ADJUSTORS (See Fig. 2)

PART NUMBER	TRACK LENGTH*
37.41.00.100	10" (254.0mm)
37.42.00.100	12" (304.8mm)
37.43.00.100	14" (355.6mm)

*Bar length is always 2" shorter than Track length.

STANDARD DUTY FRICTION ADJUSTORS (See Fig. 3)

PART NUMBER	TRACK LENGTH*
37.35.00.100	8" (203.2mm)
37.36.00.100	10" (254.0mm)
37.37.00.100	12" (304.8mm)
37.38.00.100	14" (355.6mm)

*Bar length is always 2" shorter than Track length.

LIMIT DEVICE WITH THE KEY RELEASE FEATURE (See Fig. 4)

PART NUMBER	TRACK LENGTH	BAR LENGTH
37.26.00.100	5" (127.0mm)	5" (127.0mm)
37.27.00.100	6" (152.4mm)	6" (152.4mm)
37.28.00.100	7" (177.8mm)	7" (177.8mm)
37.29.00.100	8" (203.2mm)	8" (203.2mm)
37.30.00.100	9" (228.6mm)	9" (228.6mm)
37.31.00.100	10" (254.0mm)	8" (203.2mm)
37.31.00.101	10" (254.0mm)	10" (254.0mm)
37.32.00.100	11" (279.4mm)	11" (279.4mm)
37.33.00.100	12" (304.8mm)	6" (152.4mm)
37.33.00.101	12" (304.8mm)	10" (254.0mm)
37.33.00.102	12" (304.8mm)	12" (304.8mm)
37.34.00.100	14" (355.6mm)	12" (304.8mm)
37.34.00.101	14" (355.6mm)	14" (355.6mm)

1. The Heavy Duty Friction Adjustor is the only one of these products that has the option of different bracket heights. If a bracket is not specified it comes with the standard .235 (6.0mm) bracket. For other available brackets see the table in figure 2.
2. The accompanying tables show the options available to you in the selection of the limit device or friction adjustors required for your specific application.

FIG. 1 APPLICATION OF TRUTH FRICTION ADJUSTORS

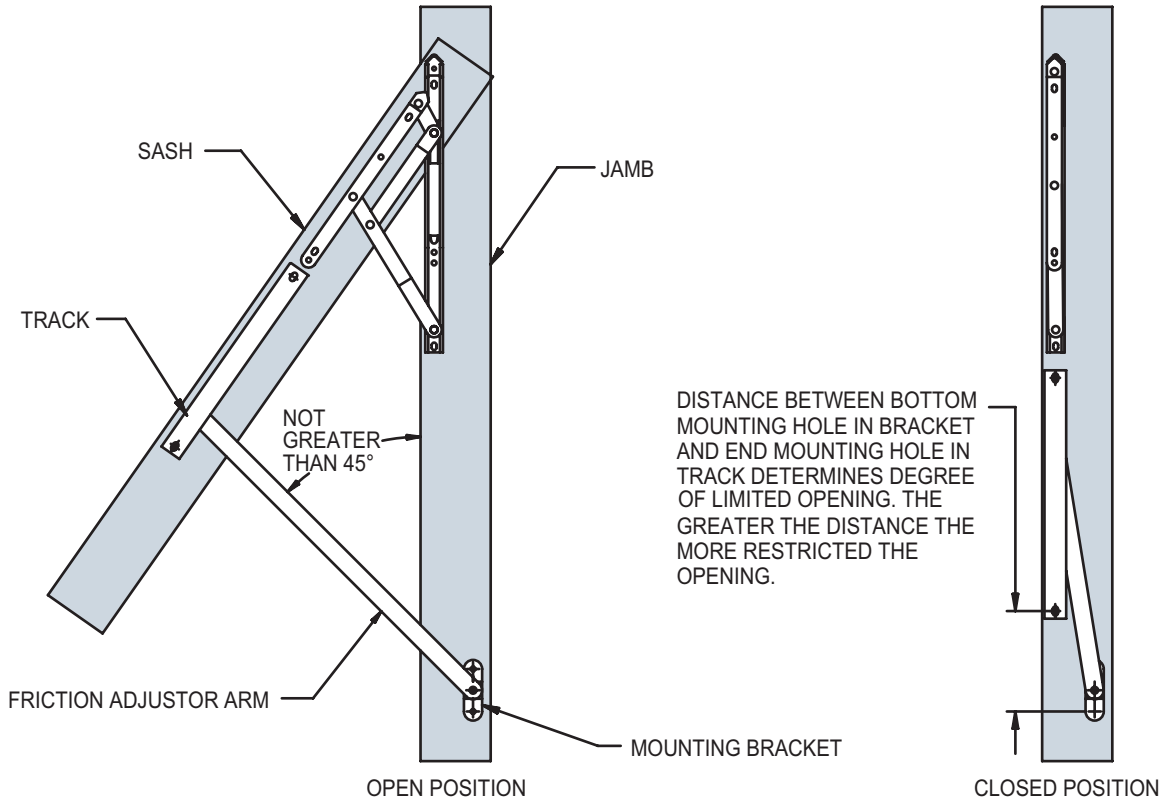

FIG. 2 TRUTH HEAVY DUTY FRICTION ADJUSTORS (Anderberg FA33SS Series)

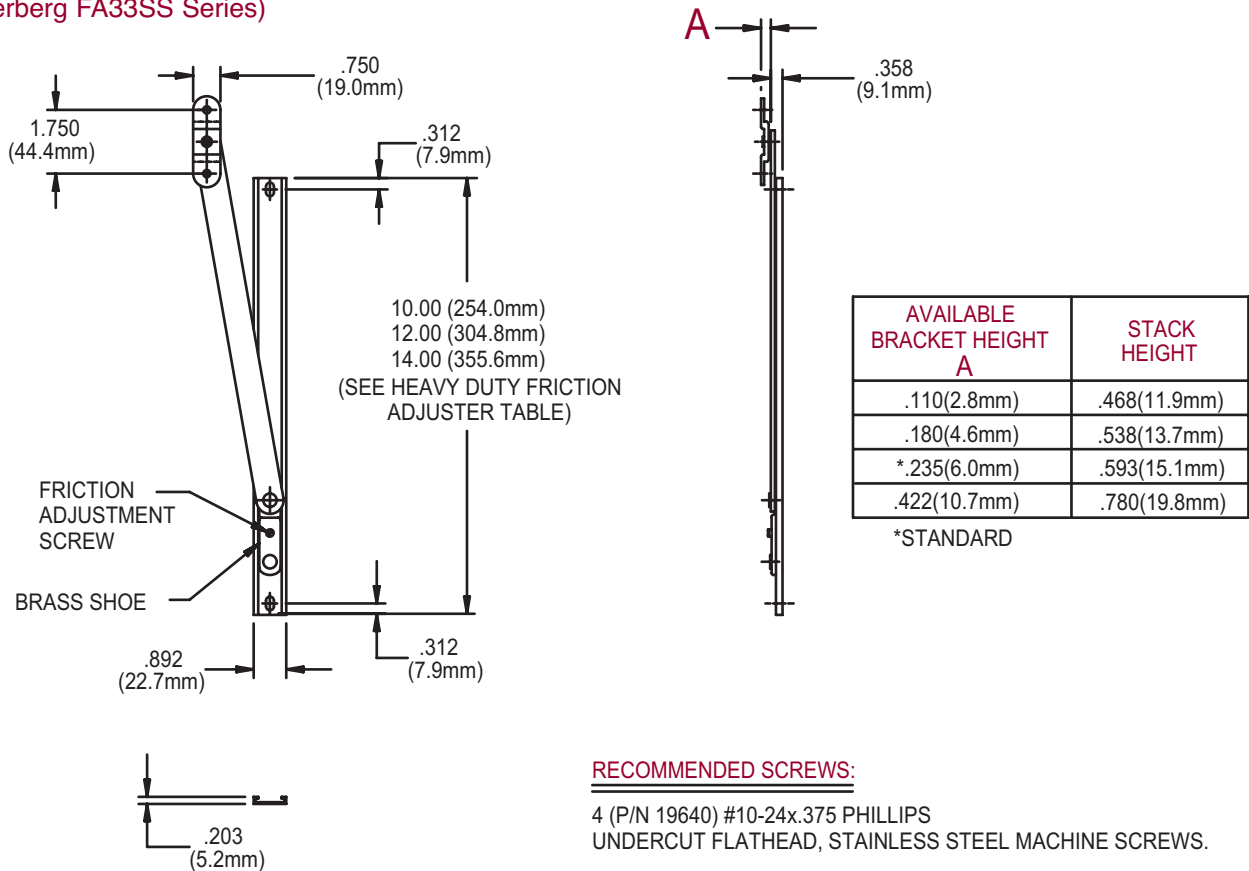
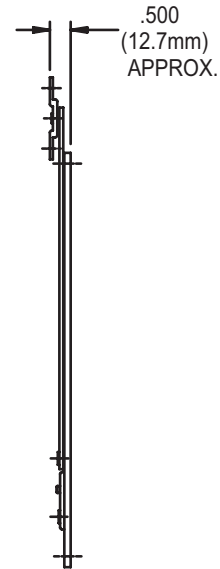
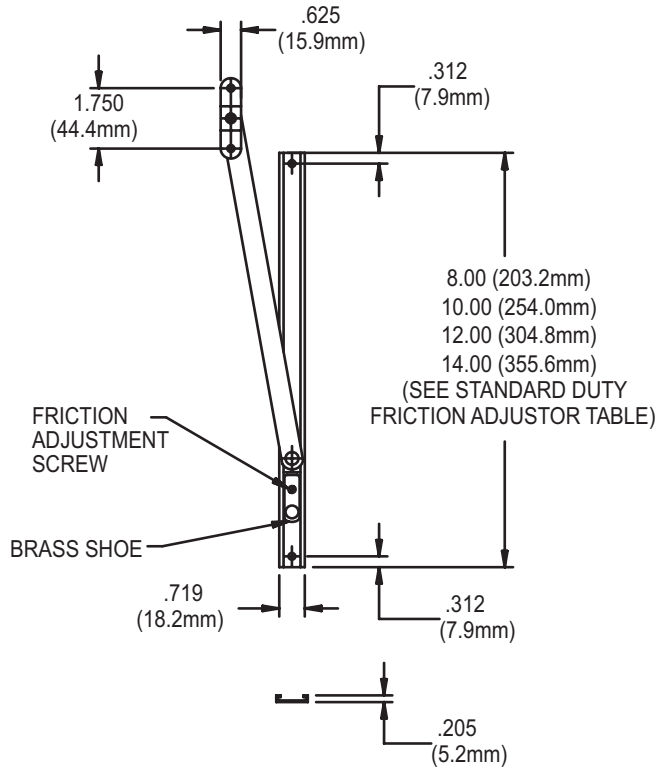

FIG. 3 TRUTH STANDARD DUTY FRICTION ADJUSTORS (Anderberg FA22SS Series)



RECOMMENDED SCREWS:

4 (P/N 19640) #10-24X.375 PHILLIPS, PAN HEAD, STAINLESS STEEL MACHINE SCREWS

FIG. 4 TRUTH LIMIT DEVICE WITH KEY RELEASE (Anderberg FA220SS Series)

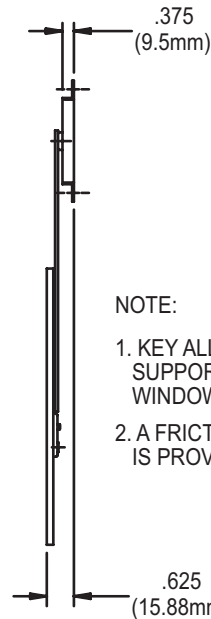
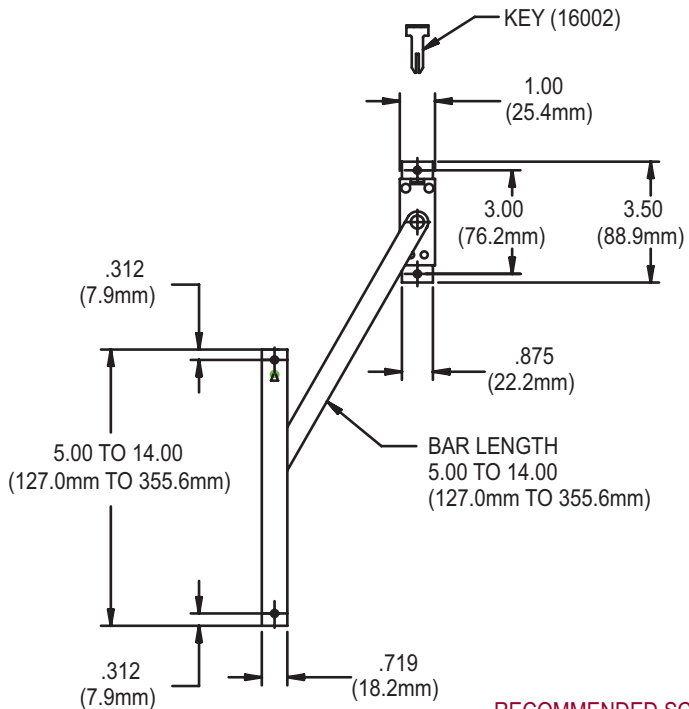

NOTE:

1. KEY ALLOWS YOU TO DETACH THE SUPPORT ARM TO OPEN THE WINDOW FURTHER FOR MAINTENANCE.
2. A FRICTION ADJUSTMENT SCREW IS PROVIDED IN THE SHOE.

RECOMMENDED SCREWS:

4 (P/N 19640) #10-24X.375 PHILLIPS, PAN HEAD, STAINLESS STEEL MACHINE SCREWS

FIG. 5 APPLICATION OF THE TRUTH LIMIT DEVICE
(When Used With Truth Concealed Casement Hinge)

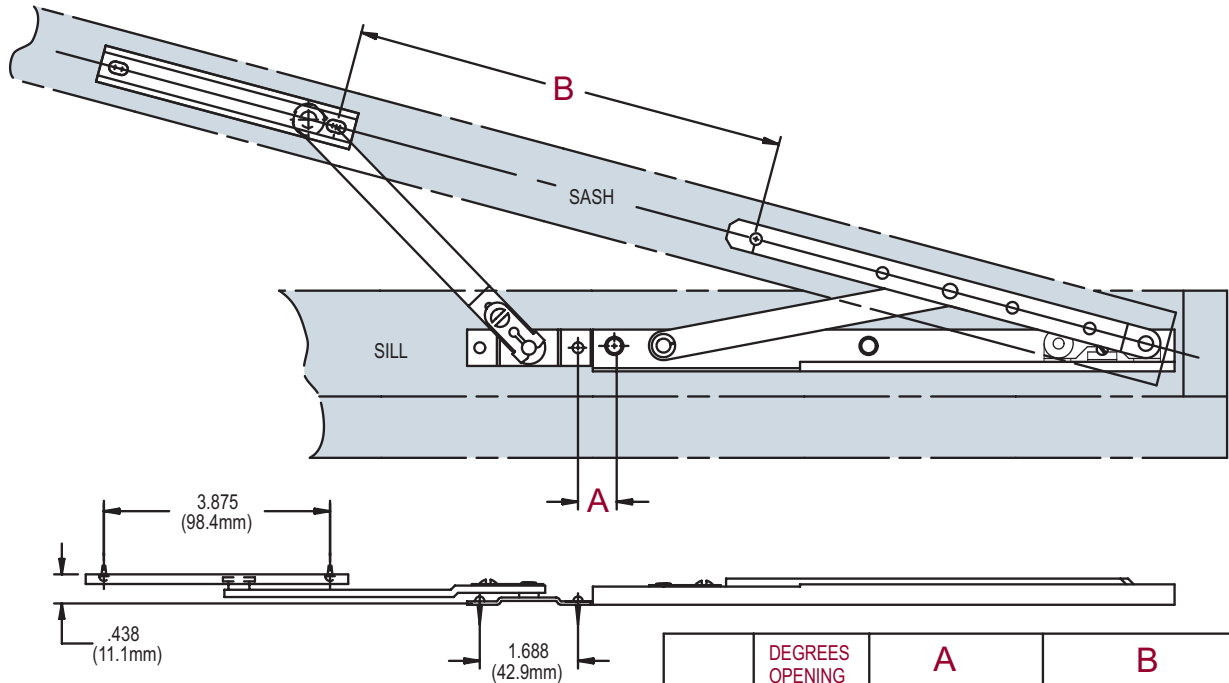

NOTE: MOUNTING DIMENSIONS MAY VARY WHEN USED WITH OTHER TYPES OF HINGES.

ADDITIONAL TYPES OF LIMIT DEVICES ARE AVAILABLE FROM TRUTH

	DEGREES OPENING	A	B
10" HINGE	5	6.125 (155.6mm)	14.188 (360.4mm)
	10	.625 (15.9mm)	8.375 (212.7mm)
	15	.625 (15.9mm)	7.656 (194.5mm)
	20	.625 (15.9mm)	6.625 (168.3mm)
13" HINGE	5	6.125 (155.6mm)	14.250 (362.0mm)
	10	.625 (15.9mm)	11.344 (288.1mm)
	15	.625 (15.9mm)	10.156 (258.0mm)
	20	.625 (15.9mm)	8.313 (211.2mm)

FIG. 6 99.20 LIMIT DEVICE

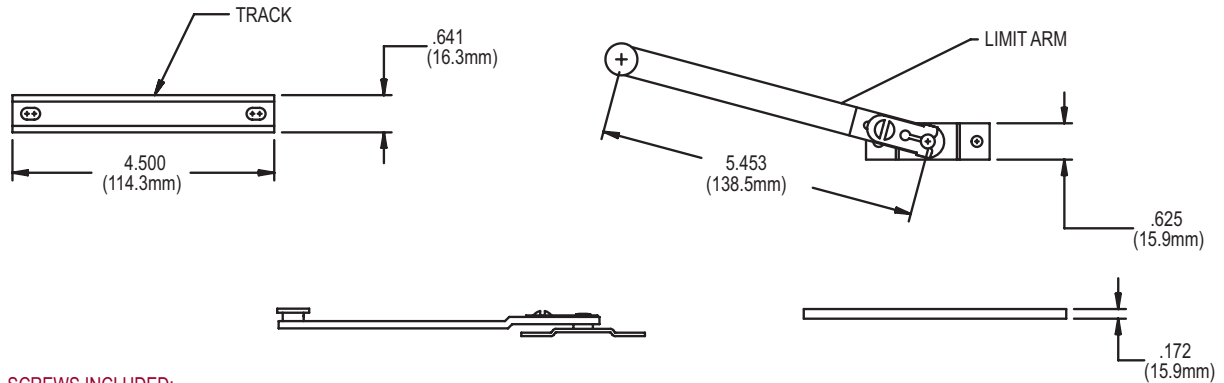

SCREWS INCLUDED:

2 (P/N 19090.92) #7 X .750 PHILLIPS, PAN HEAD, STEEL SHEET METAL SCREWS (BKT) - SUPPLIED WITH PRODUCT

2 (P/N 19091.92) #7 X .750 PHILLIPS, PAN HEAD, STAINLESS STEEL SHEET METAL SCREWS (TRACK) - SUPPLIED WITH PRODUCT

FIG. 7 APPLICATION OF TRUTH SUPPORT ARMS

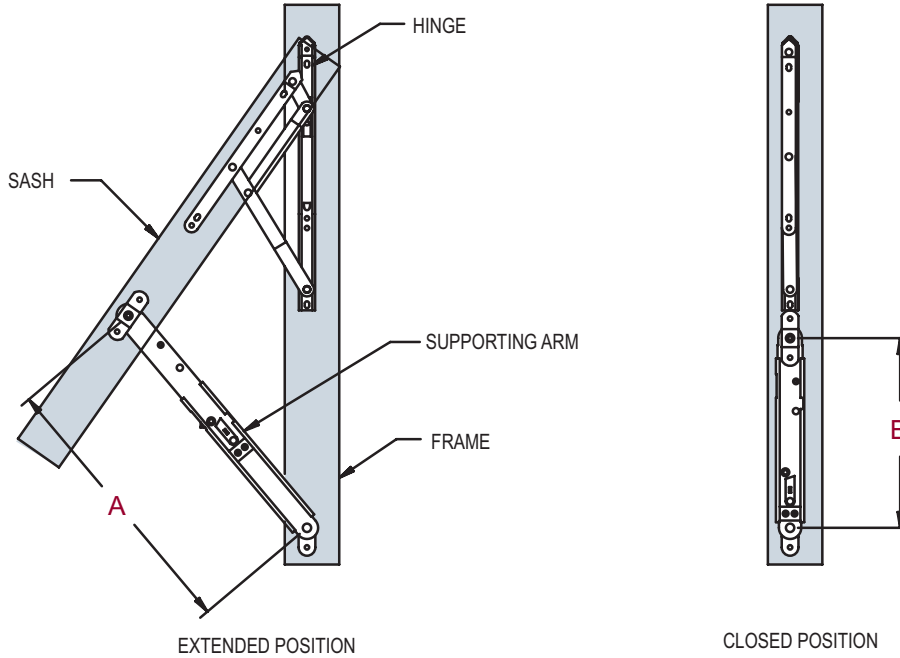

FIG. 8 TRUTH SUPPORT ARMS (Anderberg 88SS Series)

PART NO.	AVAILABLE LENGTHS	
	A EXTENDED POSITION	B CLOSED POSITION
37.10	10(254.0mm)	7(177.8mm)
37.11	12(304.8mm)	8(203.2mm)
37.12	14(355.6mm)	9(228.6mm)
37.13	16(406.4mm)	10(254.0mm)
37.14	18(457.2mm)	11(279.4mm)
37.15	20(508.0mm)	12(304.8mm)
37.16	22(558.8mm)	13(330.2mm)
37.17	24(609.6mm)	14(355.6mm)
37.18	26(660.4mm)	15(381.0mm)
37.19	28(711.2mm)	16(406.4mm)



C AVAILABLE BRACKET HEIGHT
.110 (2.8mm)
.180 (4.6mm)
.235 (6.0mm)
.422 (10.7mm)

RECOMMENDED SCREWS:

4 (P/N 19640) #10-24x.375 PHILLIPS UNDERCUT FLATHEAD, STAINLESS STEEL MACHINE SCREWS.

FIG. 9 TRUTH SUPPORT ARMS W/LIMITED OPENING (Anderberg 880SS Series)

PART NO.	AVAILABLE LENGTHS	
	A EXTENDED POSITION	B CLOSED POSITION
37.20	12(304.8mm)	8.5(215.9mm)
37.21	16(406.4mm)	10.5(266.7mm)
37.22	20(508.0mm)	12.5(317.5mm)
37.23	24(609.6mm)	14.5(368.3mm)
37.24	28(711.2mm)	16.5(419.1mm)

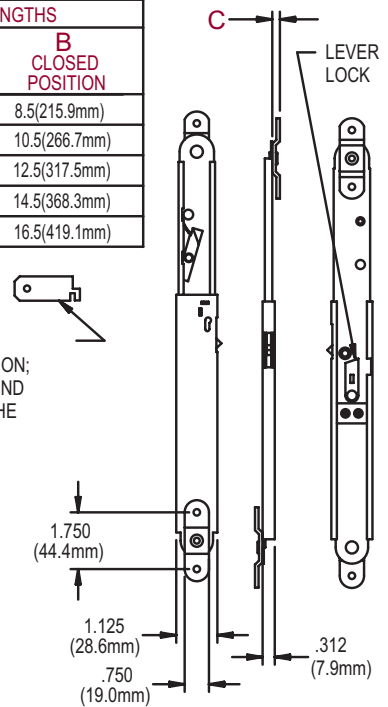

USE RELEASE KEY (16001) TO ACHIEVE MAX. EXTENSION; THIS UNIT WILL ONLY EXTEND 1.500 (38.1mm) WITHOUT THE RELEASE KEY INSERTED

C AVAILABLE BRACKET HEIGHT
.110 (2.8mm)
.180 (4.6mm)
.235 (6.0mm)
.422 (10.7mm)

RECOMMENDED SCREWS:

4 (P/N 19640) #10-24x.375 PHILLIPS UNDERCUT FLATHEAD, STAINLESS STEEL MACHINE SCREWS.