

SECTION A-A
SCALE 1 / 4

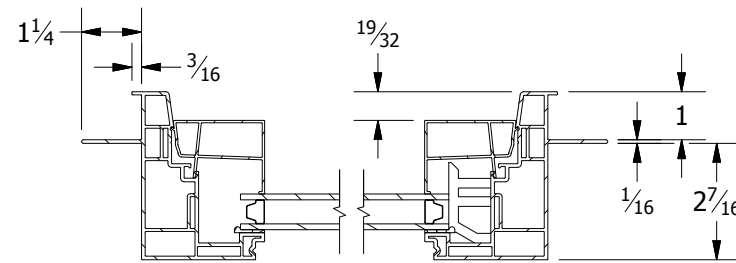

SECTION B-B
SCALE 1 / 4

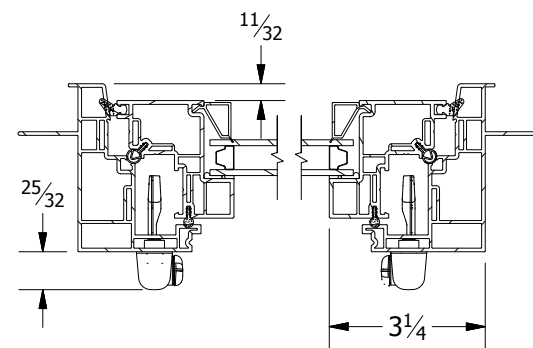

SECTION C-C
SCALE 1 / 4

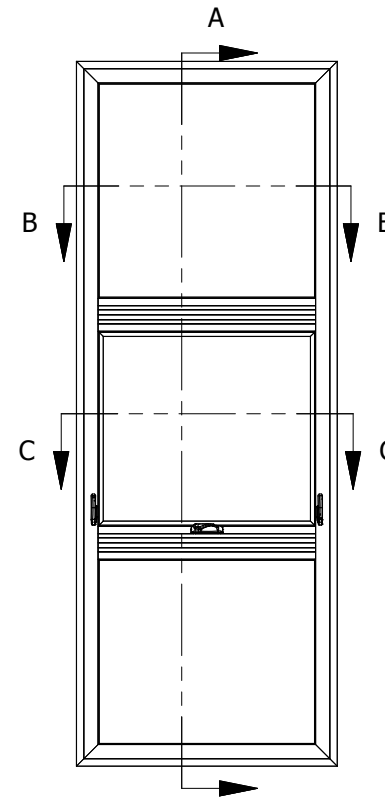

INTERIOR
SCALE 1 / 32



JAMB
SCALE 1 / 32

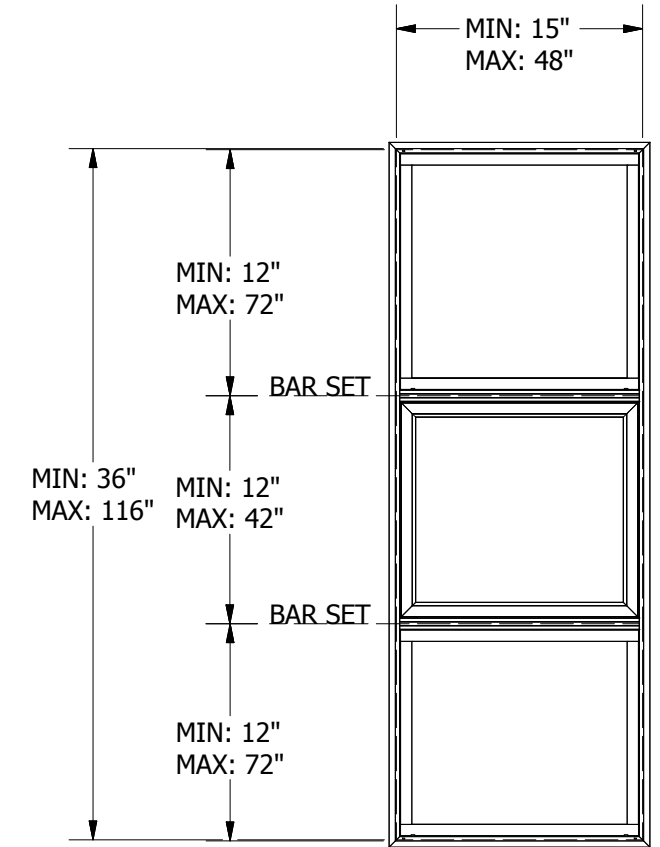

EXTERIOR
SCALE 1 / 32

TOLERANCE DECIMAL X.X ± 0.100 X.XX ± 0.025 X.XXX ± 0.005 FRACTIONAL X/X ± 1/32 ANGULAR X ± 1.0° X.X ± 0.2°	DRAWN bputre 3/8/2018	 3420 E Ferry Ave. Spokane, WA 99202 • www.vpiwindows.com <small>THIS DOCUMENT IS PROPRIETARY AND CONFIDENTIAL. NO PART OF THIS DOCUMENT MAY BE DISCLOSED IN ANY MANNER TO A THIRD PARTY WITHOUT THE PRIOR WRITTEN CONSENT BY VPI QUALITY WINDOWS.</small>
	CHECKED	
	APPROVED	
	SIZE B SCALE 1 / 32 SHEET 1 of 1	
PRODUCT FAMILY 511 ENDURANCE PROJECT	SHEET AWN-AU LAYOUT	REV