

SECTION A-A  
SCALE 1 / 4

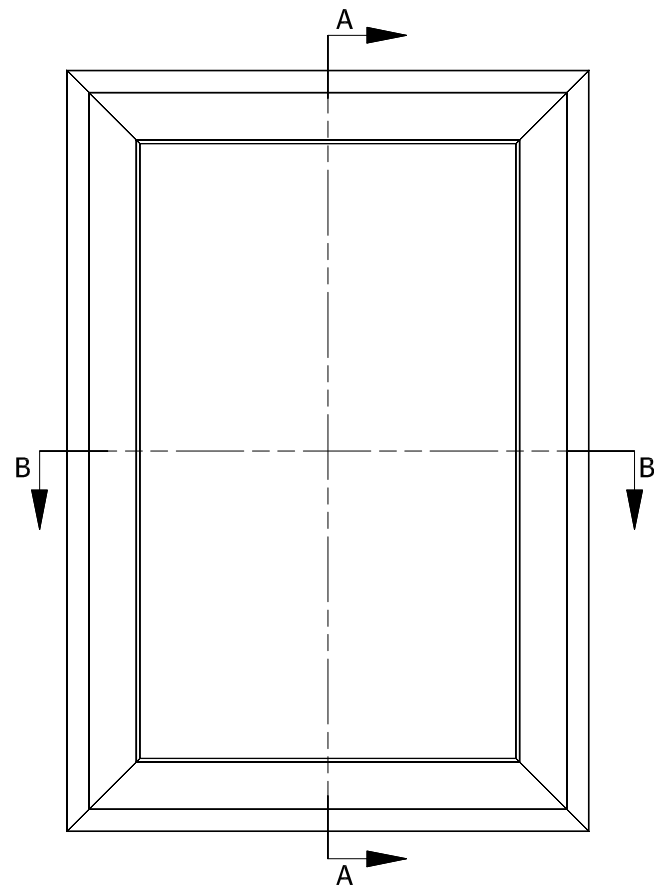

INTERIOR  
SCALE 1 / 10

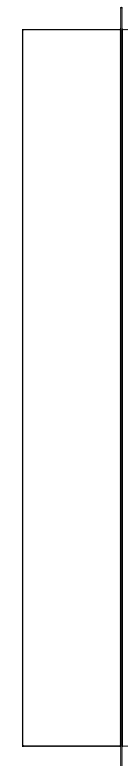

JAMB  
SCALE 1 / 10

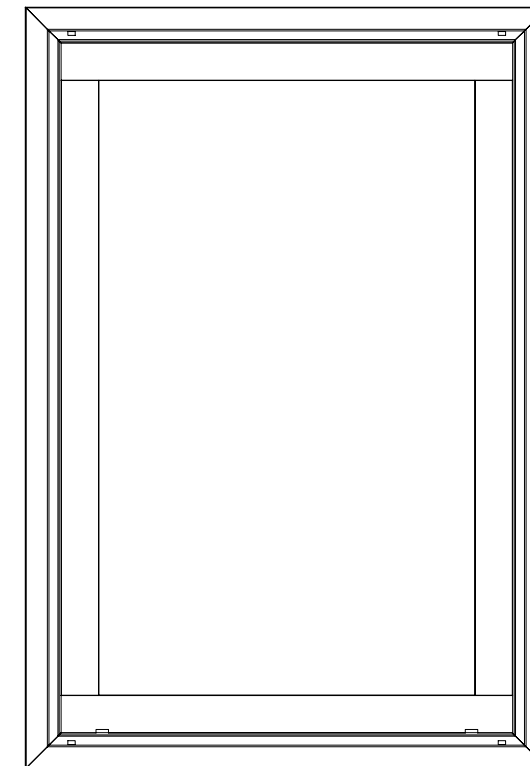

EXTERIOR  
SCALE 1 / 10

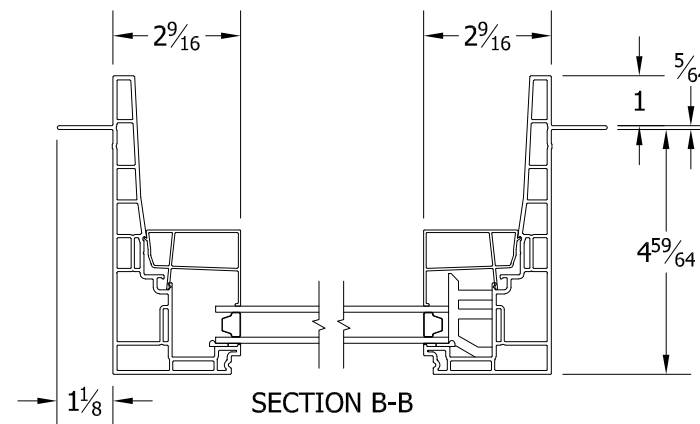

SECTION B-B  
SCALE 1 / 4

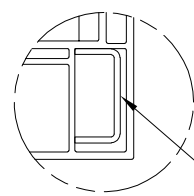

DETAIL C  
SCALE 1 / 2

SILL REINFORCEMENT INSTALLED IN FRAMES:  
LARGER THAN 40 SQ.FT. OR  
SILLS 95" AND LARGER OR ON  
CUSTOMER REQUEST

<b>TOLERANCE</b> DECIMAL X.X ± 0.100 X.XX ± 0.025 X.XXX ± 0.005 FRACTIONAL X/X ± 1/32 ANGULAR X ± 1.0° X.X ± 0.2°	DRAWN bpoutre	5/30/2018	
	CHECKED		
	APPROVED		
	SIZE B SCALE 1 / 10 SHEET 1 of 1		
PRODUCT FAMILY <b>510 - 511 ENDURANCE</b>	PROJECT		SHEET 511 PW W/NAIL FIN
3420 E Ferry Ave. Spokane, WA 99202 • www.vpiwindows.com <small>THIS DOCUMENT IS PROPRIETARY AND CONFIDENTIAL. NO PART OF THIS DOCUMENT MAY BE DISCLOSED IN ANY MANNER TO A THIRD PARTY WITHOUT THE PRIOR WRITTEN CONSENT BY VPI QUALITY WINDOWS.</small>			REV