

SECTION A-A
SCALE 1 / 4

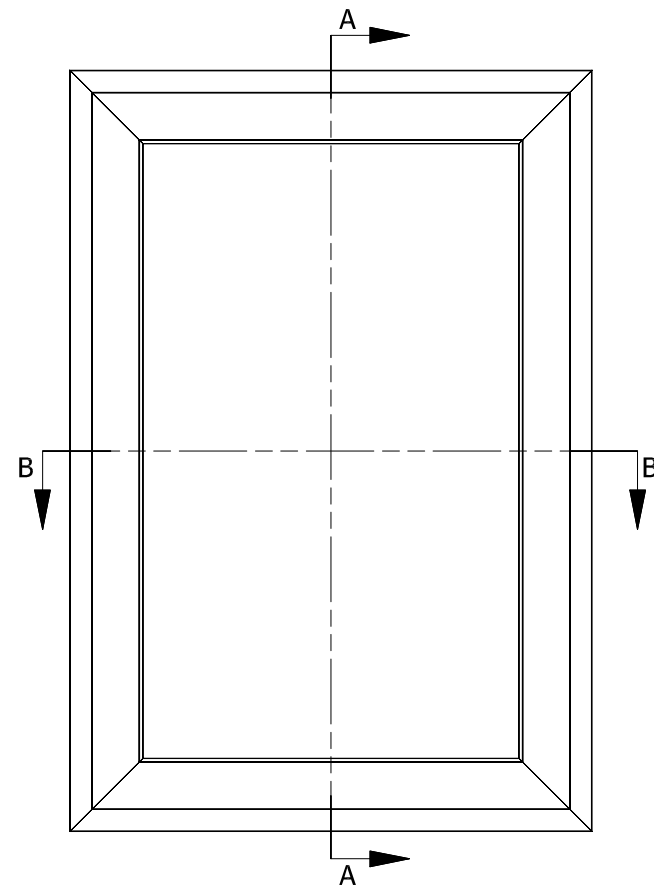

INTERIOR
SCALE 1 / 10

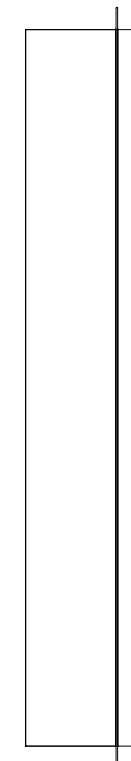

JAMB
SCALE 1 / 10

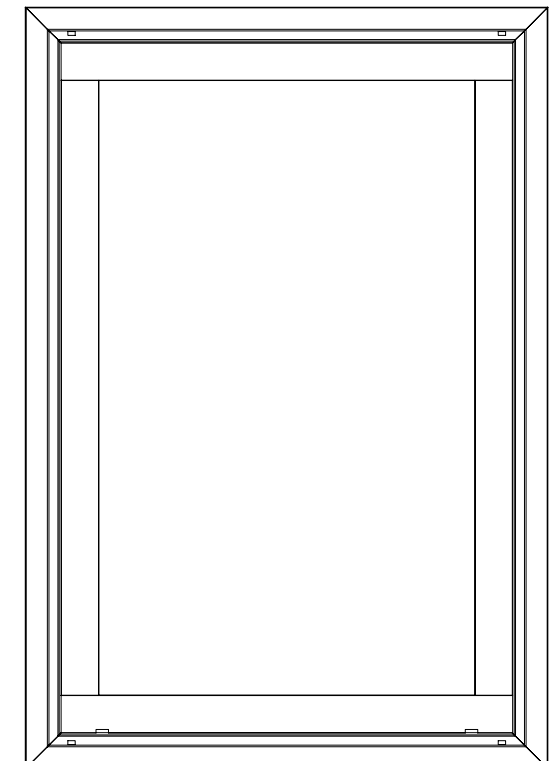

EXTERIOR
SCALE 1 / 10

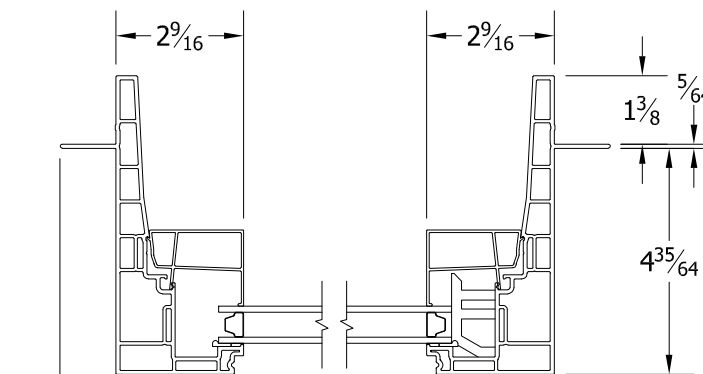

SECTION B-B
SCALE 1 / 4

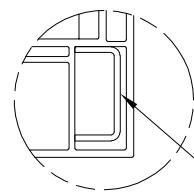

DETAIL C
SCALE 1 / 2

SILL REINFORCEMENT INSTALLED IN FRAMES:
LARGER THAN 40 SQ.FT. OR
SILLS 95" AND LARGER OR ON
CUSTOMER REQUEST

TOLERANCE DECIMAL X.X ± 0.100 X.XX ± 0.025 X.XXX ± 0.005 FRACTIONAL X/X ± 1/32 ANGULAR X ± 1.0° X.X ± 0.2°	DRAWN bpoutre	5/30/2018	
	CHECKED		
	APPROVED		3420 E Ferry Ave. Spokane, WA 99202 • www.vpiwindows.com THIS DOCUMENT IS PROPRIETARY AND CONFIDENTIAL. NO PART OF THIS DOCUMENT MAY BE DISCLOSED IN ANY MANNER TO A THIRD PARTY WITHOUT THE PRIOR WRITTEN CONSENT BY VPI QUALITY WINDOWS.
SIZE B	SCALE 1 / 10	SHEET 1 of 1	
PRODUCT FAMILY	510 - 511 ENDURANCE		
PROJECT			
	SHEET 511 PW W/NAIL FIN		REV