

SECTION A-A
SCALE 1 / 4

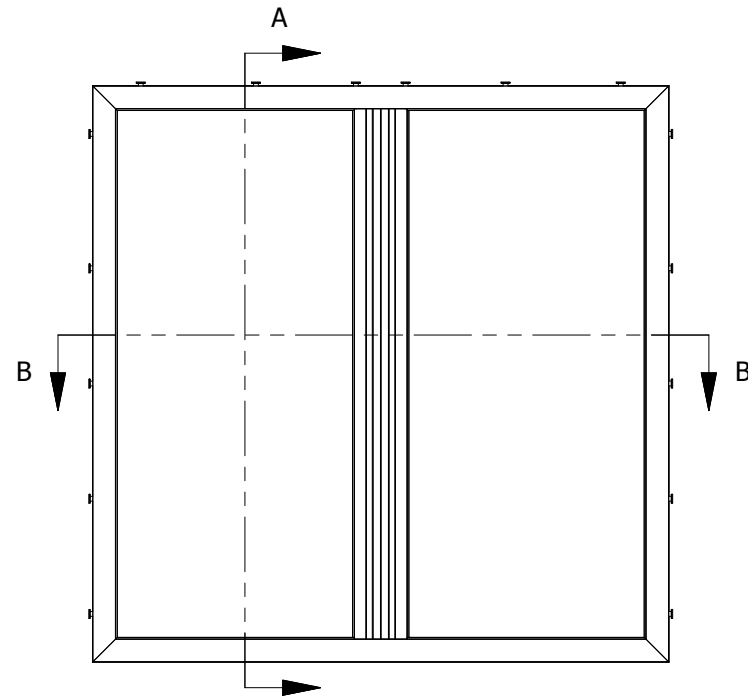

A INTERIOR
SCALE 1 / 20

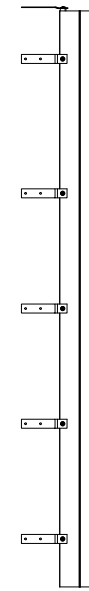

JAMB
SCALE 1 / 20

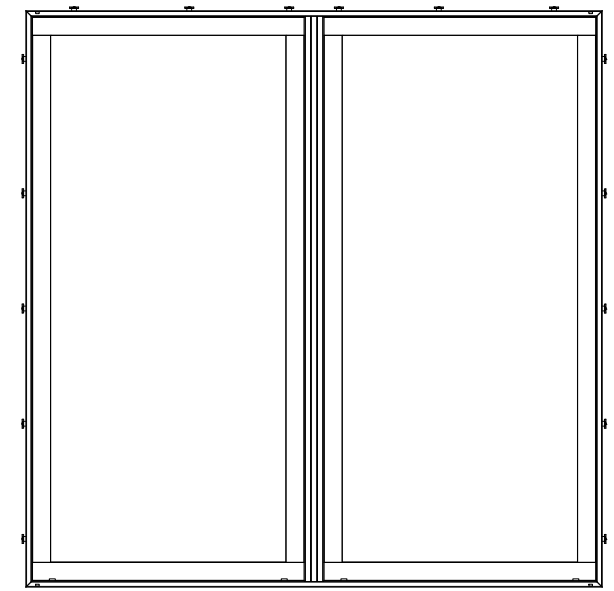

EXTERIOR
SCALE 1 / 20

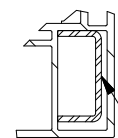

DETAIL C
SCALE 1 / 2

SILL REINFORCEMENT INSTALLED IN FRAMES:
LARGER THAN 40 SQ.FT. OR
SILLS 95" AND LARGER OR ON
CUSTOMER REQUEST

STEEL AND STRAP INSTALLED IN FRAMES:
PER INSTALLATION REQUIREMENTS

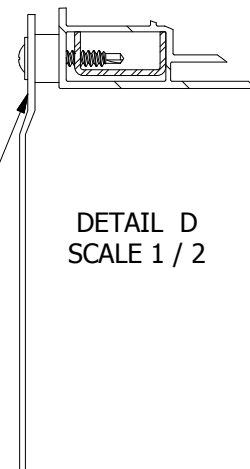

DETAIL D
SCALE 1 / 2

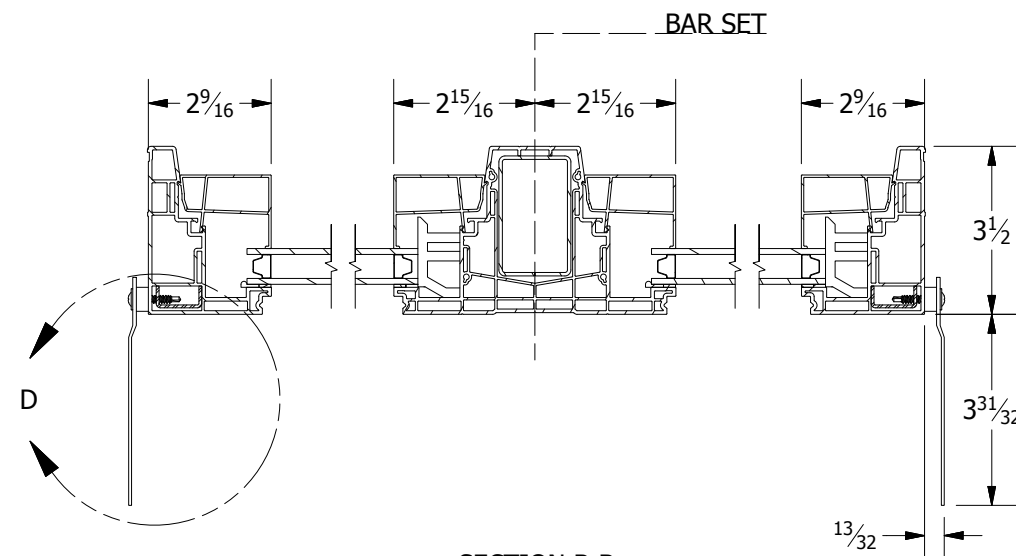

SECTION B-B
SCALE 1 / 4

TOLERANCE	DRAWN	12/18/2017
DECIMAL	bputre	
X.X ± 0.100	CHECKED	
X.XX ± 0.025	APPROVED	
X.XXX ± 0.005	SIZE	B
FRACTIONAL	SCALE	1 / 20
X/X ± 1/32	SHEET	1 of 1
ANGULAR	PRODUCT FAMILY	
X ± 1.0'	510 - 511 ENDURANCE	
X.X ± 0.2'	PROJECT	



3420 E Ferry Ave. Spokane, WA 99202 • www.vpiwindows.com
THIS DOCUMENT IS PROPRIETARY AND CONFIDENTIAL. NO PART OF THIS DOCUMENT MAY BE DISCLOSED
IN ANY MANNER TO A THIRD PARTY WITHOUT THE PRIOR WRITTEN CONSENT BY VPI QUALITY WINDOWS.

SHEET
2H-PW W/O FIN & W/ STEEL AND STRAP

REV